



Colorado Technology Student Association

2017
Call to Conference &
State Competitive
Events Guide
Parent Edition

Updated 8/30/2016



Contents

From the State Advisor	4
About COTSA.....	12
National Affiliation	12
State Conference.....	13
Student Safety	13
Website.....	13
State Officer Application	13
Dress Code.....	14-15
Deadlines.....	16
State Officers.....	17
Fleece For Fighters	18
Judging.....	19
COTSA Alumni.....	21
Website and Social Media	21
Awards & Recognition	22
Achievement Awards (Gold/Silver/Bronze).....	22
Chapter Excellence Award	22
Dr. Bob Hanson Distinguished Student Award	22
TSA Technology Honor Society	22
Advisor of the Year	23
Outstanding Recognition Award	23
Distinguished Service Award	23
Honorary Life Award	23
Distinguished Alumni Award	24
Jesse Kitchens Memorial TSA Scholarship	24
Future STEM Teacher Scholarship.....	24
William P. Elrod Memorial Scholarship	24
Johnson & Wales University Scholarship	24
Goodheart-Wilcox State Advisor of the Year Award	24
TSA Star Recognition	25
COTSA Conference Forms.....	26
Medical Release Form.....	27
Personal Liability Form	28
Photo/Media Release Form.....	29
Conference Conduct & Practices Form	30
ACS Contribution Form	31



Documentation Style Guide.....	32
Style Guide Introduction	33
General Guidelines	33
Specific Guidelines	34
The Documentation	38
State Competitive Event Rules.....	49
Catapult Design	50
Crash Test.....	55
Creativity Challenge - HS	60
Creativity Challenge - MS.....	60
Fashion Design - MS	62
Fore!	67
Giant Jenga Tournament	70
Integrated Autonomous Vehicle.....	72
Mousetrap Tractor Pull	78
On-Demand Video Challenge - MS	81
Pin Design	85
Rat Trap Drag Race.....	88
Rubber Band Powered Cars.....	91
Silent Movie	94
T-Shirt Design.....	100
Theatrical Set Design	104
Underwater ROV	111
Event Summaries - Middle School	115
Event Summaries - High School.....	126
Early Deadline Events - Middle School	139-140
Early Deadline Events - High School.....	141-142
Middle School Event Eligibility.....	143-144
High School Event Eligibility	145-146



From the State Advisor

Dear Chapter Advisors:

On behalf of our State Association, I want to welcome you to Colorado TSA and a new year of fun and excitement!

Whether this is your first time with Colorado TSA or you are an experienced veteran, I'm certain that you'll find a wealth of information in the pages that follow! There have been numerous changes to TSA's competitive events as well as the development of a new leadership program called L.E.A.P., which stands for "Leadership. Achievement. Education. Personal Growth." I will outline the updates and changes here, along with the dates and deadlines you'll need to keep your chapter moving, growing and achieving!

Mark Your Calendar

Mark your calendar now for the 31st Annual Colorado TSA State Conference which will be held February 23-25, 2017 at the Marriott Denver Tech Center, 4900 S. Syracuse Street, Denver, CO 80237. The conference returns to the Marriott after a one-year hiatus while the hotel underwent an extensive renovation! The rooms have been upgraded and the meeting space updated and expanded.

Call to Conference

This Call to Conference/State Competitive Event Guide serves several important functions. First, it is a comprehensive guide for advisors. Within these pages, advisors will find all the information regarding the state conference, including hotel rooming information, room rates, conference forms, etc., a chapter needs to get ready for the conference.

Second, this guide contains the rules and rubrics for the STATE-ONLY competitive events. These events are developed by Colorado TSA staff in conjunction with advisors and business and industry representatives from all over our state. They supplement the competitive events presented in the National TSA Competitive Events Guides. As a reminder, each year, the state-only events are reviewed and revised and new events are added or deleted. Students and advisors should **REVIEW AND CAREFULLY READ ALL THE EVENT GUIDELINES AND SPECIFICATIONS!** Do not assume the rules are the same as last year or a project may end up being disqualified for following an out-of-date rule!

A summary of each of the national events is also included at the back of this guide. Please consult the latest TSA competitive events guides for more detailed descriptions and information. Updates and clarifications for national events are made periodically throughout the year and are posted online at the national TSA website at <http://www.tsaweb.org/Updates-and-Clarification>. Please visit this website often to stay on top of all updates and clarifications.



Back are the various versions of this document – each one geared to a specific stakeholder in our organization – one for advisors, one for students, and one for parents.

- The ADVISOR EDITION -- the most comprehensive document, containing all the official conference forms (including hotel reservation forms, medical release, code of conduct forms, etc.), chapter deadline information, competitive event rules for the state-only events, as well as links to the update page, and the COTSA Documentation Style Guide.
- The STUDENT EDITION – this edition contains everything STUDENTS need for the state conference including competitive event rules for the state-only events as well as links to the update page, and the COTSA Documentation Style Guide.
- The PARENT EDITION – this edition contains information on the conference PARENTS need to know, including where and when to pick up students from the conference and the forms they will need to complete for COTSA.

Parent/Guardian Conference Attendance

Colorado TSA understands the importance and value parents/guardians have to our members. We appreciate their encouragement, enthusiasm and support. However, with the enormous growth we have experienced, we have also seen a rise in the numbers of parents/family members of student attendees coming to our conference hoping to observe the various events. It's such a significant increase in numbers that we do not have the capacity or facilities to accommodate them at the conference. For the safety of our students, volunteers, COTSA staff and hotel staff, ***access to all TSA events is restricted to officially registered and badged conference participants ONLY***. Just like any professional conference, any individual who is not an officially registered participant of the conference WILL NOT be admitted to any TSA event at the conference hotel.

We understand that families do come to pick up their students after the awards ceremonies to help chapters save money on transportation costs, and that is acceptable. However, parents and family members may not wait in the lobby, restaurant or atrium areas of the hotel for their students. Instead, they must wait outside the hotel in the hotel parking lot in designated parking spaces. They cannot wait in the hotel loading zones or fire lanes. We regret having to take this measure, but we are guests of the Marriott and we need to be respectful of their facilities and their other guests, as well as comply with local fire codes and laws.

Fleece for Fighters

The State Officers are again running the Fleece for Fighters project where each COTSA chapter is encouraged to create at minimum of two fleece-tie blankets to be donated to a pediatric cancer hospital. A flyer with instructions on how to participate is published later in this guide. The schools with the most blankets donated will be recognized at the state conference.

State Conference

Our organization continues to grow at an incredible rate; last year was our largest state conference ever. With that growth have come some significant changes to our schedule and our hotel accommodations. Here are some of them:



Early Submission: Many events have an EARLY SUBMISSION deadline. What this means is that something for these events must be submitted by the February 1, 2017 via our online system. Please refer to the Eligibility Charts later in this guide for more information on which events have Early Submit requirements and what those requirements are. Students can upload their files (PDFs for documentation and URLs for videos and multimedia presentations) via the links provided in the descriptions of those events which have Early Submit requirements. Before students can submit materials, they will need to have their state conference ID number which means they must be registered for the state conference.

Hotels: We have made arrangements with both the Marriott and the Hyatt Denver Technology Center for hotel rooms for our conference attendees. Priority at the Marriott will be given to middle school chapters first. Schools with a middle and high school chapter together will also be given priority at the Marriott. High schools will overflow to the Hyatt and students should exercise extreme caution when crossing Union to get to conference events and should also allow plenty of time to get there safely.

Hotel Reservations: This year, all hotel reservations will go through the Colorado TSA State Office. Please refer to the Hotel Reservations section further on in this guide for more information. Do NOT make your reservations directly with the hotel.

Judges: Each chapter in attendance at the State Conference is required to provide one judge per 10 students. It is preferred that the judges NOT be chapter advisors, but rather key stakeholders in each chapter's community – school administrators, school district officials, community leaders or advisory committee members. Parents are welcome, but they should not volunteer to judge a competition in which the chapter they are affiliated with is competing.

Competitive Events: This year, the National High School Competitive Event guide underwent revision. Several events were eliminated or combined with other events while others were updated/revised. It cannot be stressed enough that advisors and students need to review ALL of the competitive event rules thoroughly. Even though on first blush an event may not appear to have changed, a careful read of the rules may uncover a small rule change that could prevent a student from being able to compete! PLEASE – read the state and national competitive event guides carefully!

Events which were added/modified:

National Events:

- ***NEW - 3D Animation*** – Participants demonstrate their knowledge of 3D animation technology and design skills to creatively solve the challenge posted on the national TSA website. Semifinalists participate in an on-site competition in which they further demonstrate their 3D design skills and proficiency in 3D animation technology.
- ***MODIFIED - Architectural Design*** – This event is a re-imagination of Architectural Renovation.
- ***MODIFIED – Children's Stories*** – This year, the event is not just looking at creating a story, but also engineering a book following a specific design brief – for example a 3-D pop-up book, or electronically-enhanced book for a specific age group.



- **NEW – Coding** – This will be an on-site event in which students bring their own computer and software and use them to solve an on-site coding challenge.
- **MODIFIED – Computer Aided Design (CAD) – Architecture** – No longer will this be limited to 2-D drawings. The emphasis will be on architectural design.
- **MODIFIED – Computer Aided Design (CAD) – Engineering** – A modification to eliminate the differentiation between 2D and 3D. The emphasis will be on engineering
- **NEW – Computer Integrated Manufacturing** – This is a combination of CNC Production and Manufacturing Prototype. The contest will employ aspects of both to create a final product.
- **MODIFIED – Fashion Design and Technology** – Modifications were done to allow for things like wearable electronics.
- **MODIFIED – Flight Endurance** – Kits will still be allowed, but the specifications have changed and scratch-built planes of the students’ own designs are encouraged.
- **MODIFIED – Photographic Technology** – The number of pictures in the portfolio have been reduced to 5 (instead of 15) and the final on-site challenge has been reduced to a single, powerful image instead of a multimedia presentation. Interview has been eliminated.
- **MODIFIED – Prepared Presentation** – This event is no longer a “memorize your speech” event. Students will be given an on-site prompt, have overnight to prepare a 5-slide presentation to give the following day.
- **NEW/MODIFIED - STEM Careers** – Career Preparation was modified to encompass STEM Careers
- **MODIFIED – System Control Technology** – Increased number of participants

Stay on top of national event rule clarifications and updates by frequently visiting the Updates and Clarifications page on the national TSA website: <http://www.tsaweb.org/Updates-and-Clarification>.

State Events:

- **NEW - Fashion Design - Middle School** – A mirror of the high school event with the same name specifically for budding middle school fashion designers.
- **NEW - On-Demand Video - Middle School** - A mirror of the high school event with the same name. Students create a short video on-site after being given a specific prompt.
- **NEW - Theatrical Set Design - High School** – A combination of CAD Architecture and Architectural Model, this event has participants design and build a model of a set for a given play.
- **NEW - Silent Movie - Middle/High School** – In this team event, students create a “silent movie” (no dialogue or sound effects) and then create a musical sound track to accompany the film in the style of the vintage silent movies.



Conference Schedule: This year, in order to accommodate the growing numbers of conference participants, the new events and the added L.E.A.P. interviews, the conference will start at 9:00 a.m. on Thursday, February 23 and go until Saturday, February 25 at approximately 2:00 p.m.

Hotel rooms may not be available for check-in until later in the day on the 23rd. However, arrangements have been made at the hotels for luggage storage until rooms are available.

There will be two opening sessions: one for high school and one for middle school. The opening session is mandatory as important TSA business will be discussed and announcements given. Please ensure that your chapter is on time and seated for your opening session.

After the second opening session, the state officer candidates will be available for a meet and greet. TSA members should visit with the candidates to help determine for whom they will vote. On Thursday evening, chapters should vote on any pending business and officer candidates and should return their ballots to conference HQ as soon as possible.

There will also be two closing/award ceremonies on Saturday: one for high school and one for middle school. During the high school awards ceremony, it is recommended that middle school chapters pick up projects and check out of the hotel so that they can leave as soon as the award ceremony is over. During the middle school awards ceremony, it is recommended that high school chapters pick up their projects and check out of hotel rooms if they have not already done so.

Dress Code: Students arriving at the conference should be dressed in TSA competition attire as noted in the rules, since competitions will be starting almost right away. Jeans, athletic shoes, and t-shirts are not acceptable competition attire. Conference dress code is addressed later in this guide.

Written Testing: This year, instead of using Scantron sheets to have students take the written tests for Chapter Team, Electrical Applications, Forensic Technology, and Tech Bowl, we will be using an online testing system. Students in these events must bring their own laptop or tablet (not cell phone) to the conference testing room to take the test(s). They will be given instructions and a code to log into the testing site. This will streamline the testing process and it eliminates the need for all students on a team to take the test together. The test questions will be randomized by the system to eliminate the possibility of impropriety. Students will need to report to the testing room during the designated testing window to take the test. They will also be required to surrender their cell phones for the duration of the test and retrieve it at the end of the testing session.

State Officer Application: If a student is interested in becoming a state officer, they must complete and submit the state officer application which is available on the Colorado TSA website (www.cotsa.ccs.edu under For Students). The requirement that a state officer candidate hold a chapter office has been removed from the application; however, students must demonstrate some of leadership that their advisor can speak to (e.g., Boy/Girl Scouts, youth groups, etc.).

Special Interest Sessions: If you would like to put on a special interest session or know of someone who would, please submit a special interest session proposal form located at: <https://goo.gl/forms/2nWOU2wcLdbbclq72>.



L.E.A.P. - Leadership. Education. Achievement. Personal Growth.

At the 2016 National TSA Conference, the national office rolled out its new leadership program called L.E.A.P. which stands for “Leadership. Education. Achievement. Personal Growth.” The purpose of L.E.A.P. is to encourage students to be the best member they can be as they seek knowledge about themselves, the organization, and their community, while demonstrating leadership. A customized program specifically developed for TSA, L.E.A.P. brings to life the TSA motto, creed, and mission statement.

Inherent to L.E.A.P.’s “Be. Know. Do” criteria are the five practices described in the Student Leadership Challenge:

- Model the Way (clarify values and set an example for others)
- Inspire a Shared Vision (enlist others to get involved in an activity based on a common goal)
- Challenge the Process (look for innovative ways to improve)
- Enable Others to Act (facilitate relationships and foster collaboration)
- Encourage the Heart (recognize contributions of others and create a spirit of community)

To embrace L.E.A.P.’s “Be. Know. Do.” criteria and realize the impact that the above five practices can have on the development of student leadership, L.E.A.P. has been integrated into each TSA competition as part of the official rules and rubric in the 2017 & 2018 High School Technology Activities, National TSA Conference Competitive Events Guide. Students should use the Student Leadership Challenge resources, in addition to other TSA website L.E.A.P. resources, as they complete the new TSA competitive event L.E.A.P. leadership resume requirement for all TSA competitions. Participants who advance to the semifinalist level of an event will be required to participate in a L.E.A.P. interview.

L.E.A.P. Leadership Resume and Interview

For 2016-17, an individual or team L.E.A.P. Leadership Resume is required for all high school competitive events, and a section of each high school event rubric is dedicated to L.E.A.P. components. At the national conference, the resume must be submitted either at event check-in or when participants arrive at an event at a designated event time, whichever applies. At the state conference, the L.E.A.P. Leadership Resume (either individual or team) is required to be included in an event’s documentation and either submitted as part of the single, multi-page documentation portfolio in PDF format, or turned in at project check-in, whichever applies.

For events with an existing semifinalist portion, the L.E.A.P. Interview will be conducted as part of the semifinalist portion of the event and will involve semifinalists responding to interview questions about their submitted L.E.A.P. Resume.

For all other events, the L.E.A.P. Interview will be conducted in a separate L.E.A.P. semifinalist portion and will involve semifinalists responding to interview questions about their submitted L.E.A.P. Resume.

L.E.A.P. Legacy Chapter

The first phase of the L.E.A.P. program includes the inclusion of L.E.A.P. resumes in all high school competitive events. Next year, in 2017-18, L.E.A.P. will be integrated into the middle school competitive events.



In addition to the individual competitive event pieces, L.E.A.P. will also have a stand-alone competitive event called the Legacy Chapter. High schools will have the opportunity to participate in the Legacy Chapter during the 2016-17 school year with middle schools following in 2017-18. Only one chapter from each level (middle school/high school) may then move on to the national level to represent our state in this competition.

As of the time of publication of this Call to Conference, the Legacy Chapter guidelines and criteria have not yet been released from the national office, but we have been told that high schools will be able to participate in this event for the 2016-17 school year.

As described, we believe this is an important and exciting development, particularly for Colorado. As we continue to grow as a state association, many of the ways in which we have recognized students and chapters for outstanding work have become outdated. One example is the Chapter of the Year award which has traditionally been awarded to those chapters who have earned the most points based on the number and type of medals earned in the various competitive events. As it stands, the Chapter of the Year award is heavily skewed in favor of larger chapters; the more students a chapter has, the more events they can enter with the maximum number that can be entered. Smaller schools, through no fault of their own, cannot compete in as many events, nor with the same number of students than their larger counterparts, and therefore could never realistically be in the running for Chapter of the Year honors but yet may be just as vital and active in the community and engaged with business and industry as their larger counterparts. To not recognize the work they do does a disservice to them as members, their school, and the people they impact on a daily basis.

We must keep in mind that TSA does not solely exist to provide a set of competitive events. TSA is one of the 10 nationally recognized career and technical student organizations which all have leadership development as one of their core tenets. With the advent of L.E.A.P., we see the Legacy Chapter program as one which could “level the playing field” and allow us as a state association to recognize chapters for the work they do as leaders in a technical world as well as technologically competitive individuals. With the Legacy Chapter, ANY chapter, regardless of size, geographic location, or socioeconomic status has the ability to achieve a high level of success. The Legacy Chapter promises to be a much more comprehensive program to help determine chapter achievement and success.

To that end, for the 2016-2017 school year, we will be piloting the Legacy Chapter program as a replacement for the current Chapter of the Year award. For 2016-17, we will still award the Chapter of the Year honors as we have in the past, but will also recognize those chapters who successfully complete the Legacy Chapter application.

As stated previously, every chapter, regardless of size, should have the ability to meet the criteria of a Legacy Chapter. Granted, it may not be on the same scale as that of a larger chapter, but it doesn't have to be; the Legacy Chapter program shifts the emphasis from the “points per medal” count of the Chapter of the Year and focuses on how impactful the students' work and personal growth are.

We will provide more information on the Legacy Chapter and its pilot phase this year in Colorado as more details become known. News and updated information will be mailed to advisors and posted on the COTSA website (www.cotsa.cccs.edu) for more information.



Documentation Style Guide

Included in this document is the Colorado TSA Documentation Style Guide which students can use to create project documentation required for many competitions. The guide helps with formatting the documentation so it meets all TSA guidelines – both national and state! The guide should be used to ensure that student projects are not disqualified because of improperly formatted documentation!

State Officer Outreach

The COTSA State Officer team wants you and your students to know they are always available to assist chapters as they establish and grow. To do this, all chapter advisors are requested to provide the name and contact emails of their chapter presidents so the state officer team can make personal contact with a chapter's officer team and work with them one-on-one to answer questions about the state conference, competitive events, running for state office, and more. To schedule a state officer visit, please go to the COTSA website at www.cotsa.cccs.edu and click on "Schedule A State Officer Visit."

Deadlines!

Please make note of all the deadlines listed in this Call to Conference. There is no flexibility with any posted deadlines and there are no exceptions! Failure to meet stated deadlines may prevent a chapter from participating in the state or national conferences! Please use the information in this document to keep track of the chapter's progress toward the deadlines throughout the year; a chart is provided showing the important dates.

Forms

Included in this document are the forms required by the state association and the hotel for participation in the state conference. ALL conference attendees are required to complete these forms. Once the forms have been completed and returned to the chapter advisor, they must be submitted **IN PDF FORMAT** to the state office. **DO NOT SEND PAPER COPIES** to the state office! NOTE: If a chapter's paperwork and/or payment are not received by the deadlines stated in this document, THE CHAPTER WILL NOT BE ALLOWED TO PARTICIPATE IN THE CONFERENCE! It takes time to process checks and get forms back, so please PLAN AHEAD!!!

Social Media

TSA members are encouraged to interact with each other and the state officers via social media. Please join Colorado TSA on Facebook and Twitter to get all the latest news and updates (Twitter: Colorado TSA; Facebook: Colorado Technology Student Association; and Instagram: colorado_tsa) and share pictures and stories! Plus, visit the COTSA web page for updates at: www.cotsa.cccs.edu.

I wish you the best of luck this year and look forward to working with all of you. If you have any questions or comments, please feel free to contact me at (720) 858-2794 or via email at: tony.raymond@cccs.edu.

Best regards,

Tony Raymond, COTSA State Advisor



About COTSA

The Colorado Technology Student Association is a national non-profit national organization of students engaged in science, technology, engineering, art and mathematics (STEAM). Open to students enrolled in or who have completed technology education courses, TSA's membership includes more than 225,000 middle and high school students in approximately 2,000 schools spanning 49 states. TSA is supported by educators, parents and business leaders who believe in the need for a technologically literate society. Members learn through exciting competitive events, leadership opportunities and much more. The diversity of activities makes TSA a positive experience for every student. From engineers to business managers, our alumni credit TSA with a positive influence on their lives.

TSA chapters take the study of STEAM (science, technology, engineering, art and mathematics) beyond the classroom and give students the chance to pursue academic challenges among friends with similar goals and interests. Together, chapter members work on competitive events, attend conferences on the state and national levels and have a good time raising funds to get there. Chapter organization develops leadership, as members may become officers within their state and then run nationally. Our chapters are committed to a national service project and are among the most service-oriented groups in the community.

Our state association, the Colorado Technology Student Association (COTSA) has been dedicated to developing leadership and personal growth in students for more than 30 years. At the state level, we are guided by a dedicated group of community, business and industry leaders, teachers, and administrators who are dedicated to ensuring that our students receive the best possible experience as a result of their involvement in TSA.

For more information about TSA or the Colorado Association, please visit our national website at <http://www.tsaweb.org> or <http://www.cotsa.cccs.edu> or contact the COTSA State Advisor, Mr. Tony Raymond, at 720-858-2794 or via email at tony.raymond@cccs.edu.

National Affiliation

Schools wishing to become members of TSA must become an affiliated chapter of the organization. The affiliation process is detailed on the national TSA website at <http://www.tsaweb.org/Affiliation-and-Dues>.

In order to compete in events at the state conference, your chapter must be affiliated with the national office no later than January 1, 2017! Chapters and individuals not registered (with all documentation completed and both state and national dues paid) with National TSA will not be allowed to compete at the state conference. **Chapters MUST affiliate with National TSA in order to receive the official TSA Competitive Events Guide for either middle or high school.**



State Conference

Each year, Colorado TSA holds an annual statewide conference which brings student members together with business, industry, and community leaders in a competitive showcase that recognizes both technological skill and leadership development.

This Call to Conference and State Competitive events guide contains the information a chapter needs to prepare for this year's state conference, including outlines of all of the national events for both middle and high school as well as the rules for the state-only contests which have been developed specifically for students in grades 6-12 (and in some cases even for elementary students) by experienced technology education teachers within Colorado.

This year's state conference will be held **February 23-25, 2017** at the **Marriott Denver Tech Center, 4900 S. Syracuse, Denver, CO 80237**.

The theme for the State Conference this year will be: "Defining Your Future." Please Note: This theme is the same as the TSA National Conference. Competitive event themes are posted on the national website at: <http://www.tsaweb.org/Themes-and-Problems>.

Student Safety

Student safety is of utmost concern to us. Therefore, we must insist that chapter advisors ensure that students have all the proper safety equipment, including safety glasses, tools and materials they need to compete successfully and safely. Please refer to the rules in the competitive event guides for specific details.

Website

Chapter members can access the COTSA website at <http://www.cotsa.cccs.edu>. The website is updated frequently and contains news and updates!

State Officer Application

There are many opportunities to serve in leadership roles in TSA: Students can be local chapter officers where they serve as leaders of their school chapter. They can also serve as state officers where they work with the state officer advisor and the state advisor at the state level. Here they serve the entire Colorado delegation through chapter visits/workshops and their work with the fall leadership, state and national conferences. If a student who is interested in becoming a state officer, they must complete and submit the state officer application which is available on the Colorado TSA website (www.cotsa.cccs.edu under For Students). All forms and questions in this packet must be signed and returned, either electronically (as an email attachment as a scanned as a PDF, which is preferred) to myka.raymond@gmail.com, with the subject line "2017 State Officer Application" or mailed as a hard copy to COTSA, c/o Tony Raymond, 9101 E. Lowry Blvd, Denver CO 80230) by 11:59 p.m. on February 1, 2017 All applications and letters of reference **must be received** by this deadline to be considered. Please be mindful that recommendation forms required from adults must be sent from the adults' own email accounts. Recommendations not sent from the proper email addresses will be rejected and the state officer application will not be accepted.



Dress Code

Chapter and state advisors, parents, and chaperones are responsible for seeing that all TSA student members wear TSA competition, general session, or casual attire as occasions may require. Official TSA attire may be purchased online via the SHOP tab on the TSA website at www.tsaweb.org. TSA competition, general session, and casual attire are considered appropriate dress for conference activities and public appearances. Since adults (advisors, parents, and guests) serve as role models at TSA conferences and activities, they are expected to dress appropriately for all TSA occasions they attend. Students must adhere to the TSA dress code requirements as listed below.

Student members must wear official TSA attire (with either the official royal blue dress shirt/blouse, or a button-down white dress shirt/blouse), professional TSA attire, or business casual TSA attire as indicated in the national or state competitive events guides. Please note that the use of a white dress shirt in lieu of the official royal blue shirt is an exception made at the state conference only. It is the expectation and is REQUIRED that students attending the NATIONAL CONFERENCE must purchase the official royal blue uniform shirt to be in compliance with national official uniform requirements.

Flip-flops, athletic shoes (tennis shoes, running shoes, etc.), army boots, combat boots or work boots are not permitted. Halter tops, tank tops and shorts are also not permitted. Hats are not to be worn at any time during the conference. Please refer to the examples of appropriate attire as shown on the next page.

All attendees MUST wear their name badges at all times.

For Chapter Team only, at both the middle school and high school levels, competitors also must wear a navy blue blazer with an official TSA patch; males (only) must wear the official TSA logo neck tie.

Refer to the attire requirements as listed in the guides for event-specific attire. Students are always allowed to dress MORE formally than specified for conference activities, and students dressed LESS formally than specified for an event in which they are competing will be allowed to compete but will be assessed a penalty of twenty percent (20%) of the total possible points.

COMPETITION ATTIRE

Shirt or blouse: official TSA shirt (royal blue)

Pants or skirt: gray

Socks: black or dark blue (males only)

Shoes: black dress shoes (unacceptable: athletic shoes, army boots, combat, or work boots)

Sandals: females only may wear black open-toe shoes or sandals

Required for middle school or high school level Chapter Team only, but may be worn for other competitions if preferred by contestant:

Blazer: navy blue with official TSA patch

Tie: scarlet red imprinted with official TSA logo (males only)



GENERAL SESSION ATTIRE

Shirt or blouse: button-up shirt with a turned down collar or a polo/golf shirt; however, the official TSA shirt (royal blue) is preferred

Dress skirt or pants: (unacceptable: jeans, baggy pants, exterior pocket pants, shorts)

Socks: black or dark blue (males only)

Shoes: dress shoes or dress boots (unacceptable: athletic shoes, combat, or work boots); females only may wear open-toe shoes or sandals



CASUAL ATTIRE

Same as general session attire, OR appropriate t-shirts, shorts, or jeans.



Registrants must wear conference identification badges at all times.



Deadlines

PAYMENT AND REGISTRATION DEADLINES ARE NOT FLEXIBLE! Failure to meet these deadlines may result in late fees and/or your chapter being unable to compete!

Deadline Date	Task To Be Completed
January 1, 2017	Deadline to complete National affiliation process. Chapters must be affiliated BEFORE registering for the state conference. To affiliate go to: http://www.tsaweb.org
October 24, 2016 - January 15, 2017	STATE CONFERENCE REGISTRATION BEGINS! * Early Bird Registration (registration completed prior to Jan. 8, 2017): \$85 * Late Registration (registration after Jan. 8 but before Jan. 15, 2017): \$90 Go to: http://www.registermychapter.com/tsa/co . All substitutions, additions and changes must be completed by midnight January 15, 2017.
January 8, 2017	Early Bird registration ends! Registration goes up after January 8, 2017!
January 15, 2017	REGISTRATION CLOSES AT MIDNIGHT - NO REGISTRATIONS OR CHANGES CAN BE MADE AFTER THIS DATE!
January 15, 2017	Online room reservations need to be completed. To claim a tax exemption, a chapter must include: <ul style="list-style-type: none"> • Sales Tax Certificate (see page 13 of this guide) • Denver Claim for Exemption Form (see page 14 of this guide) • Credit Card Affidavit (see page 16 of this guide) • Affidavit of Non-Taxable Sale to Tax-Exempt Organization (see page 17 of this guide) <p>Hotel Rooming Lists should be sent to Tony Raymond, in PDF format via email: tony.raymond@cccs.edu. Payment arrangements must be made directly with the hotel.</p>
February 1, 2017	All state officer applications must be completed and received, including reference letters.
February 1, 2017	All forms and registration payments are due by this date or your chapter will not be allowed to complete! Payments can be via check or online with a credit card. PAYMENT BY CHECK: Checks should be made payable to: Colorado TSA, 9101 E. Lowry Blvd., Denver, CO 80230 PAYMENT BY CREDIT CARD: Payments can be made anytime at: http://bit.ly/1NvkrOz . Please note that a 4% convenience fee will be added to the invoice for payments made via credit card.
Feb. 23-25, 2017	State Conference
June 21 - 25, 2017	National TSA Conference - Rosen Shingle Creek, Orlando, FL

State Officers

In addition to educating students about technology and its role in our global society, TSA strives to prepare the youth of today for the world of tomorrow by providing various leadership training and development opportunities for its members.

Colorado TSA encourages its members to take an active role in the organization by becoming a State Officer! State Officers are critical elements to our association. Receiving extensive leadership training, the State Officers serve as ambassadors for our organization and make frequent visits to schools promoting TSA. They are also integral to the planning, preparation and execution of the Fall and State conferences.

To be eligible to run for a state officer position, a student must have good academic standing, have attended at least one COTSA state conference (even as a middle school student), and be able to attend state officer training in mid-June, the national conference at the end of June, and the Fall and State conferences.

The state officer applications and forms, plus additional information can be found on the Colorado TSA website at <http://cotsa.cccs.edu/for-students/>. The application must be completed, signed and returned by February 1, 2017 in order to be eligible to run for office.

For more information contact Dr. Myka Raymond, COTSA State Officer Advisor at myka.raymond@gmail.com, or via phone at 720-886-5112.





Colorado TSA Presents



Fleece For Fighters



Our Mission:

Fleece for Fighters is a community service project created by Colorado TSA to create fleece-tie blankets for pediatric cancer patients.

WHY DONATE?

The Colorado TSA State Officers feel it is important to give back to those in need. This service project supports and comforts children who are living with cancer. Join Colorado TSA in the fight against cancer and make a positive impact today!

HOW TO HELP

We need your help to raise money and supplies to make this project a success. There are three things you can do:

1. Donate money to our Go Fund Me page at www.gofundme.com/fleeceforfighters. With these donations, we will buy materials needed to make blankets.
2. Donate supplies. Contact Tony Raymond at 720-858-2794 or at tony.raymond@cccs.edu and we will come to you for the supplies you have collected. Each blanket requires three yards of fleece fabric.
3. Donate blankets. You can create the blankets yourself! Here is an instructional guide on how to make the blankets: www.wikihow.com/Make-a-Fleece-Tie-Blanket. Then contact Tony Raymond and we will pick them up, or you can bring them to the state conference in February!

WE CHALLENGE YOU!

Show us what your chapter can do! Create at least two blankets in your school's colors (or gather the equivalent material). We want to see all of COTSA's chapters represented. Every bit counts, so join the Fleece for Fighters project today!



Judging

Judging at the COTSA State Conference is a very important task and one we need everyone's help doing - especially with the growth we have seen in our state association!

Mirroring the processes at the National level, every chapter is required to provide judges for the state conference. Each chapter should provide a minimum one judge for every 10 students that chapter brings to the conference (of course, more are always welcome!). For example, if a chapter registers 20 students for the state conference, they are required to provide two (2) judges; if a chapter registers 30 students, they would be required to provide three (3) judges, etc. If a chapter registers fewer than 10 students, they would only need to provide one (1) judge.

Chapters may designate parents, administrators, community leaders or members of the program's advisory committee as judges. Having every chapter provide someone to help judge events increases the efficiency of the state conference and helps ensure judging accuracy. Besides, this is a great way to involve the school and community in the good work the TSA Chapter does!

Chapter advisors should not serve as judges. However, chapter advisors should serve as event coordinators for the various competitive events. As an event coordinator, advisors would be responsible for helping set up the event (i.e., set up of equipment), obtaining supplies from conference HQ, answering questions the judges may have about the event's guidelines, and helping verify scores and potential rule violations. This role will allow more flexibility for chapter advisors to help supervise their students.

Advisors: If there is an event you would like to coordinate, or you have the contact information for judges, contact Lexi Shilling at leximschilling@gmail.com, Shannon Viegel at shannonveigel@icloud.com or Tony Raymond, Colorado TSA State Advisor at tony.raymond@cccs.edu. We would like to have all judges in place as early as possible to aid in the conference planning process.

Both event coordinators and contest judges will be required to attend a JUDGING ORIENTATION prior to the start of the contest. The orientation is designed to ensure that:

- Judges have read all rules and are familiar with them.
- Judges are clear on expectations for judging the event and scoring.
- All judges can have their questions answered BEFORE there is an issue.
- Provide instructions on how to properly complete score sheets.
- Provide instructions on when scores are due in conference headquarters.
- Judges are connected to their specific Event Coordinator in case questions arise during competition.
- **IMPORTANT NOTE:** Even if someone has been a judge in an event before, they will still need to attend a Judging Orientation Session!



Can you build the tallest Jenga tower?

If you think you can, then don't forget to register to participate in the GIANT JENGA TOURNAMENT at the 2017 COTSA State Conference! At stake are the Traveling Jenga Trophies which the winning middle and high schools can proudly display for a year before bringing them back to the conference when they defend their title!

* * *

Each chapter can register up to 4 teams of 2-4 students each to play in the tournament. To register for the GIANT JENGA TOURNAMENT, Advisors register each team just as they would for any other team event at the conference. Simply login to the COTSA State Conference website and for each student on a team, select GIANT JENGA TOURNAMENT as one of their events and indicate which team they are on!

It's that easy!

Then, at the State Conference, battle it out for GIANT JENGA bragging rights against other TSA chapters!

The winners will be announced at the Awards Ceremony and will be awarded the Traveling Jenga Trophies!

COTSA Alumni Association

The Alumni of the Colorado Technology Student Association is a dynamic group of individuals who have participated as student members of our organization. Each year, this dedicated group of people volunteer their time to help out at the state conference! We couldn't put on as successful an event as we do without their help!

Colorado TSA is always looking for ways to reconnect with alumni and keep them involved! Alumni, or those interested in being an alumni member after graduation, should sign up with the Colorado TSA Alumni Association. It's a simple process...just visit: <https://goo.gl/forms/RctscNvP4aGzidXR2> and complete the



online form or sign up at the state conference at the alumni booth! It's absolutely free! And...you get the opportunity to participate in the TSA conference as alumni next year! Advisors are encouraged to have all of their graduating seniors to sign up for the Alumni Association!

Interested individuals can also connect with the alumni association by visiting the Alumni Facebook page at <http://www.facebook.com/pages/Colorado-Technology-Student-Association-Alumni/280880062723>.

Website and Social Media

Colorado TSA maintains an active web presence through its web page and social media, including pages on Facebook as well as Twitter. Everyone is welcome to join our online ranks!

Do you have photos of your chapter doing community service, working on projects, participating in meetings, or just having fun? If so, send them to Tony Raymond, the COTSA State Advisor, for posting on the Facebook and web pages! It's a great way for to network with fellow TSA members and promote a school's chapter and activities. Photos should be sent to tony.raymond@cccs.edu and should include name(s), location(s), date(s) and a brief description for each photo.

For news, updates, forms, and association-related information, check out the COTSA website at <http://www.cotsa.cccs.edu>!



Awards & Recognition

There are a number of opportunities for students and advisors to be recognized through TSA, and we strongly encourage both students and advisors to take advantage of these great programs! For application forms and complete information, please visit the national TSA website at the following addresses:

- www.tsaweb.org/Student-Achievement-Awards
- www.tsaweb.org/Student-Scholarships
- www.tsaweb.org/Adult-Achievement-Awards

Achievement Awards (Gold/Silver/Bronze)

The TSA Achievement Program (bronze, silver, and gold awards) is designed to motivate and recognize student members for high effort in a school's technology education program. The TSA Achievement Program is an opportunity for every TSA member to strive and receive recognition for accomplishments and is designed to encourage excellence in the areas of leadership development, understanding technology, school/community service, and career/personal planning. This program is also planned so the highest awards represent outstanding individual performance. This noncompetitive, self-initiated program encourages students to develop appropriate attitudes and increase their knowledge and skills through involvement in technology education programs and activities.

Chapter Excellence Award

The Chapter Excellence Award recognizes those chapters who have developed and implemented a successful program of work including chapter involvement (at local, state, and national conferences, with the community, and other TSA chapters); financial leadership activities; leadership activities; and involvement with alumni.

Dr. Bob Hanson Distinguished Student Award

The recipient of the Distinguished Student Award is selected on the basis of valued service to the community and to TSA. Both past and present contributions are considered. Criteria for eligibility include: Active member in good standing with TSA for a minimum of one school year; active participation in TSA at the local, state, or national level; and recognition by fellow students, teachers, or administrators of technology education programs as a student who has achieved prominence and distinction.

TSA Technology Honor Society

The TSA Technology Honor Society recognizes TSA members who excel in academics, leadership, and service to their school and community. The TSA Technology Honor Society is an opportunity for student members to be recognized for their efforts and is designed to recognize TSA members who exemplify the high ideals of academics.



Advisor of the Year

Students are encouraged to submit the name of their chapter advisor to the state office for the Annual Advisor of the Year award. The honoree is recognized at the state conference and then again at the National Conference for their outstanding work with TSA.

Dr. Harvey Dean Outstanding Recognition Award

The recipient is selected on the basis of valued service contributing to the growth of TSA. Both past and present contributions are considered (as verified by responsible parties). The criteria are as follows:

- The organization(s) that the recipient represents has supported TSA in some capacity at the local, state, or national level for a minimum of three years
- Active participation, as evidenced by attendance at the conferences, membership on committees, judging student events, etc.
- Efforts to advance TSA, as evidenced by encouraging business personnel and industrial leaders to support TSA activities

Distinguished Service Award

The recipient is selected on the basis of valued service to TSA. Both past and present contributions are considered (as verified by responsible parties). The criteria are as follows:

- Associated with TSA in some capacity for a minimum of three years
- Active participation as evidenced by attendance at the conferences, membership on committees, judging student events, etc.
- Involvement with advancing TSA as evidenced by work in professional education groups, publications, research, etc.
- High standard of attainment as shown by establishment of new TSA chapters, program expansion or innovation, or by achievement of student members who have achieved prominence and distinction
- Recognition by fellow professionals as indicated by similar awards from local, district, state or regional groups.

Honorary Life Award

Recipient has supported TSA in a significant way for a minimum of five years and is a person from whom TSA may reasonably expect continued interest in its activities.



Distinguished Alumni Award

The recipients (three per year) of this award are alumni of TSA who have demonstrated commitment and service to TSA beyond graduation. The criteria are as follows:

- Graduated from high school at least three years prior, after being a member in good standing with TSA for a minimum of two years
- Active participation since graduation, as evidenced by attendance at the conferences, membership on committees, judging student events, or other service of value to TSA.

Jesse Kitchens Memorial TSA Scholarship

This Colorado-based scholarship is granted to a TSA member to help with their college education in memory of Jesse Kitchens, a COTSA member. Members must be in good standing, display dedication and passion for TSA. More information can be found on the COTSA web page at <http://www.cotsa.cccs.edu> or at www.tsacarshow.com.

Future STEM Teacher Scholarship

The purpose of the Future STEM Teacher Scholarship is to support the STEM education profession by encouraging promising TSA students to pursue careers as K-12 STEM teachers.

William P. Elrod Memorial Scholarship

The scholarship is awarded for outstanding service in the field of technology to a TSA student who is college, university or career and technical school bound and who is in good academic standing, OR to a TSA alumnus/a currently enrolled in an undergraduate program or a career and technical school.

Johnson & Wales University Scholarship

Johnson & Wales University offers \$1000-full tuition National Student Organizations scholarships to TSA members. For more information and apply online at <http://www.jwu.edu>

Goodheart-Wilcox State Advisor of the Year

The recipient will have demonstrated significant support on behalf of TSA for a minimum of five years and is an individual from whom TSA may reasonably expect reliable and continued interest in its activities.



TSA Star Recognition

This award is a state-level award that provides recognition to those Colorado TSA chapters and members who actively assist new or lapsed TSA chapters in becoming active members. It is through these efforts that TSA continue to grow! Has your chapter assisted a new or inactive TSA chapter (middle or high school) with the affiliation process for this year? If so, we want to know about it so that your chapter receives Star recognition! Each chapter that helps a new chapter affiliate receives Star lapel pins and is recognized on the COTSA website. Pins are awarded on the following criteria:

- White Star Recognition 1 to 2 new TSA chapters
- Blue Star Recognition 3 to 5 new TSA chapters
- Red Star Recognition 6 or more new TSA chapters



COTSA Official Forms

Parents: On the next few pages, are several forms that need to be completed and turned in by the deadlines listed in this guide. These forms **CANNOT AND WILL NOT BE ACCEPTED ON SITE AT THE CONFERENCE!!! IF YOUR STUDENT'S CHAPTER DOES NOT HAVE THESE FORMS TURNED IN BY THE DEADLINE, THEY WILL NOT BE ALLOWED TO COMPETE IN THE CONFERENCE.** All of these forms, and most certainly others required by your child's school and district, will be sent to you from the chapter advisor. Please return all forms to the chapter advisor.

Medical Release Form

This form must be completed by EVERY conference participant, including advisors, chaperones and observers. This information is critical in the event of an emergency and needs to be kept by the advisor at the state conference. **THESE FORMS ARE TO BE KEPT BY THE CHAPTER ADVISOR IN THE EVENT OF AN EMERGENCY. DO NOT TURN THESE FORMS INTO THE STATE OFFICE.**

Personal Liability Form

This form is to be completed by EVERY conference participant, including advisors, chaperones and observers. This form is to be turned in to the state advisor.

Photo Release Form

This form must be completed by EVERY conference participant, including advisors, chaperones and observers. This form grants us the rights to take pictures at the conference to promote Colorado TSA.

Attendee Conduct & Practices Signature Form

This form is to be completed by EVERY conference participant, including advisors, chaperones and observers. It is to be turned in to the state advisor.

American Cancer Society Donation Form

In an effort to help our national charitable partner, the American Cancer Society, Colorado TSA is providing conference attendees the opportunity to donate to this worthy cause. If any conference participant would like to donate, they simply need to complete the form located in this guide. All American Cancer Society Donation Forms/Checks are to be sent via USPS to the COTSA State Office and not submitted online. Send all ACS donations to: Colorado TSA, c/o Tony Raymond, 9101 E. Lowry Blvd., Denver, CO 80230. **Make checks/money orders payable to American Cancer Society.**



Medical Release Form

**REQUIRED BY ALL STUDENTS & ADULTS
ATTENDING THE COTSA STATE CONFERENCE
(TO BE KEPT BY EACH CHAPTER ADVISOR - PRINT CLEARLY)**

Student: _____
Advisor: _____ School: _____

Medical Information

Date of Birth: _____

Known allergies (drugs or otherwise): _____

Date last tetanus shot administered: _____

Medication currently being taken: _____

Describe any history of heart condition, diabetes, and asthma, epilepsy, or rheumatic fever, etc.: _____

Physical restrictions (swimming, running, etc.) _____

Relative's name: _____ Best Contact Number: (_____) _____

Physicians name: _____

Insurance Information

Medical Insurance Co.: _____

Identification / Policy No.: _____

Subscriber's Name: _____ Phone: (_____) _____

Subscriber's place of employment: _____

I, _____ (parent/guardian) hereby authorize any physician member of the Department of Emergency Medicine of an accredited hospital or any member of the medical staff of an accredited hospital to render medical treatment, which is in his/her judgment may be deemed necessary in the care of

(child/student) while attending the Colorado Technology Student Association State Conference (including time traveling to and from the conference).

Parent / Guardian signature

Date

ADVISORS – PLEASE NOTE:

**This form is to be kept by you, the local chapter advisor, at the conference and given to the appropriate medical authorities in a medical emergency!
DO NOT TURN THIS FORM INTO COLORADO TSA!**



Personal Liability Form

REQUIRED BY ALL STUDENTS & ADULTS ATTENDING THE COTSA STATE CONFERENCE

**ALL FORMS MUST BE UPLOADED TO
COTSA STATE CONFERENCE FORM UPLOAD SITE (<http://goo.gl/yrxWYF>)
NO LATER THAN FEBRUARY 1, 2017.**

Name of Participant: _____
Date of Birth: _____
School: _____
School Address: _____
Home Phone: (_____) _____ School Phone: (_____) _____

"I hereby agree to release the Colorado Technology Student Association (COTSA) and the Colorado Community College System, its representatives, agents, servants, and employees from liability for any injury to the above named person at any time while attending the Colorado State Technology Student Association's State Conference, including travel to and from the conference, excepting only such injury or damage resulting from willful acts of such representatives, agents, servants, and employees."

"I do voluntarily authorize the Colorado Technology Student Association's State Conference chair, assistants and/or designees to administer and/or obtain routine or emergency diagnostic procedures and/or routine or emergency medical treatment for the above named person as deemed necessary in medical judgment."

"I agree to identify and hold harmless the Technology Student Association, Inc., the Colorado Technology Student Association, the Colorado Community College System and said conference chair and/or assistants and designees for any and all claims, demands, actions, rights of action, and/or judgments by or on behalf of the above named person arising from or on account of said procedures and/or treatment rendered in good faith and according to accepted medical standards."

Adult/Parent or Guardian (if child or student)

Date

Participant

Date



Photo/Media Release Form

REQUIRED BY ALL STUDENTS & ADULTS ATTENDING THE COTSA STATE CONFERENCE

ALL FORMS MUST BE UPLOADED TO
COTSA STATE CONFERENCE FORM UPLOAD SITE (<http://goo.gl/yrxWYF>)
NO LATER THAN FEBRUARY 1, 2017.

I hereby consent to and authorize the use and reproduction by Colorado TSA, the Colorado Community College System (CCCS), or anyone authorized by Colorado TSA or CCCS, of any and all photographs/digital images/videotapes/recordings of:

Attendee's Name

from the February 23-25, 2017 Colorado State Technology State Conference at the Marriott Denver Tech Center/Hyatt Regency Denver Tech Center for use by Colorado TSA and/or the Colorado Community College System (CCCS), its employees, officers and agents, and the right to copyright and/or use, reuse and/or publish, republish photographic pictures, digital images, video tapes and recordings in conjunction with the above named individual's own name.

I also give permission for these photographic/digital images/videotapes/recordings to be used in its entirety and/or edited version as deemed necessary by Colorado TSA and/or CCCS (to include usage of images on Career and Technical Student Organization (CTSO) websites, including, but not limited to Facebook).

Furthermore, permission is also given for the photographs/digital images/videotapes/recordings completed on February 23-25, 2017 to be used by Colorado TSA and/or CCCS at any time in the future without further clearance from me.

I understand that these photographs/digital images/videotapes/recordings may be used for marketing purposes (including websites) by Colorado TSA and CCCS. I have read the foregoing release, authorization and agreement, before signing below, and warrant that I fully understand the contents thereof.

I hereby grant permission for photographing, videotaping and/or recording.

Signature of Parent/Guardian* or Individual

Date

* If individual is under 18 years of age.

Address: _____

City: _____

State: _____

Zip: _____

NOTE: Any student who is subject to harassment due to the publishing of photos (either in publications or on the websites) should contact the State Advisor immediately.



Conference Conduct & Practices

REQUIRED BY ALL STUDENTS & ADULTS ATTENDING THE COTSA STATE CONFERENCE

**ALL FORMS MUST BE SIGNED BY THE ATTENDEE, PARENT, ADVISOR AND PRINCIPAL AND
UPLOADED TO COTSA STATE CONFERENCE FORM UPLOAD SITE (<http://goo.gl/yrxWYF>)
NO LATER THAN FEBRUARY 1, 2017.**

1. The term “attendee” shall mean any student or adult attending the conference and taking part in its activities.
2. Identification badges must be worn at all times by persons in conference attendance.
3. There shall be no defacing of public property. Any damages to the property or furnishings in the hotel rooms or buildings must be paid by the individual(s) or school(s) responsible.
4. Attendees shall keep their advisors informed of their activities and/or whereabouts at all times.
5. Attendees should be prompt and prepared for all activities.
6. Attendees should be financially prepared for all possibilities.
7. All attendees must stay at conference hotel.
8. No attendee shall remain in the sleeping room of the opposite gender unless the door is open at all times.
9. No attendee shall remain in the sleeping room of the opposite gender past curfew.
10. No conference attendee shall possess any alcoholic beverages, narcotics or firearms, in any form at any times, under any circumstances.
11. Smoking will not be permitted.
12. No attendee shall leave the conference hotel (except for authorized events) unless permission has been received from their chapter advisor(s).
13. Attendees are required to attend all general sessions and activities assigned, including workshops, all general sessions, competitive events, committee meetings, etc., for which they are registered, unless engaged in some specific assignment taking place at the same time.
14. Chapter advisors will be responsible for their attendees’ conduct.
15. Attendees violating any of the conduct rules will subject their entire delegation to being removed from the conference or disqualified from competition.
16. The Colorado State Conference committee reserves the right to dismiss any attendee (adult or student) from the conference for inappropriate actions.

Attendee:

I have read and completely understand the COTSA State Conference Attendee Conduct Practices and Procedures Code. I do hereby agree to follow the procedures and practices described. I fully understand that this is an educational activity and will, to the best of my ability, apply myself for the purpose of learning and will uphold the finest qualities of a person representing my school.

Attendee Signature

Date

Parent/Guardian, Advisor/ Teacher, & Principal:

I approve the student named above to attend the 2017 Colorado Technology Student Association State Conference in Denver, CO on February 23-25, 2017.

Parent/Guardian Signature

Advisor/Teacher Signature

School Principal Signature



ACS Contribution Form



During the school year, TSA chapters all across the country are encouraged to include in their Program of Work an activity that benefits the National TSA National Service Project - our work with the American Cancer Society. Chapters can engage in a number of activities, including participating in a Relay for Life event. Relay for Life is the ACS's signature event that offers chapters and schools a fun, healthy opportunity in the fight against cancer. The money raised by the individual chapters helps the vital research, education, advocacy, and patient services of the American Cancer Society.

In addition to recognizing chapters at the national conference for their overall contributions to the ACS, individuals can also help our National Service Project and contribute to the American Cancer Society directly.

If you would like to help Colorado TSA support the efforts of the American Cancer Society by making a donation, please do so using the form below and include your donation (with checks or money orders made payable to the American Cancer Society) with your student's registration form.

Thank you for your time, commitment and generosity.

Name:

School:

Donation Amount: \$15 \$25 \$50 \$100 Other _____

All American Cancer Society Donation Forms/Checks are to be sent via USPS to the COTSA State Office and not submitted online.

Send all ACS donations to: Colorado TSA, c/o Tony Raymond, 9101 E. Lowry Blvd., Denver, CO 80230.

Make checks/money orders payable to American Cancer Society.



Documentation Style Guide

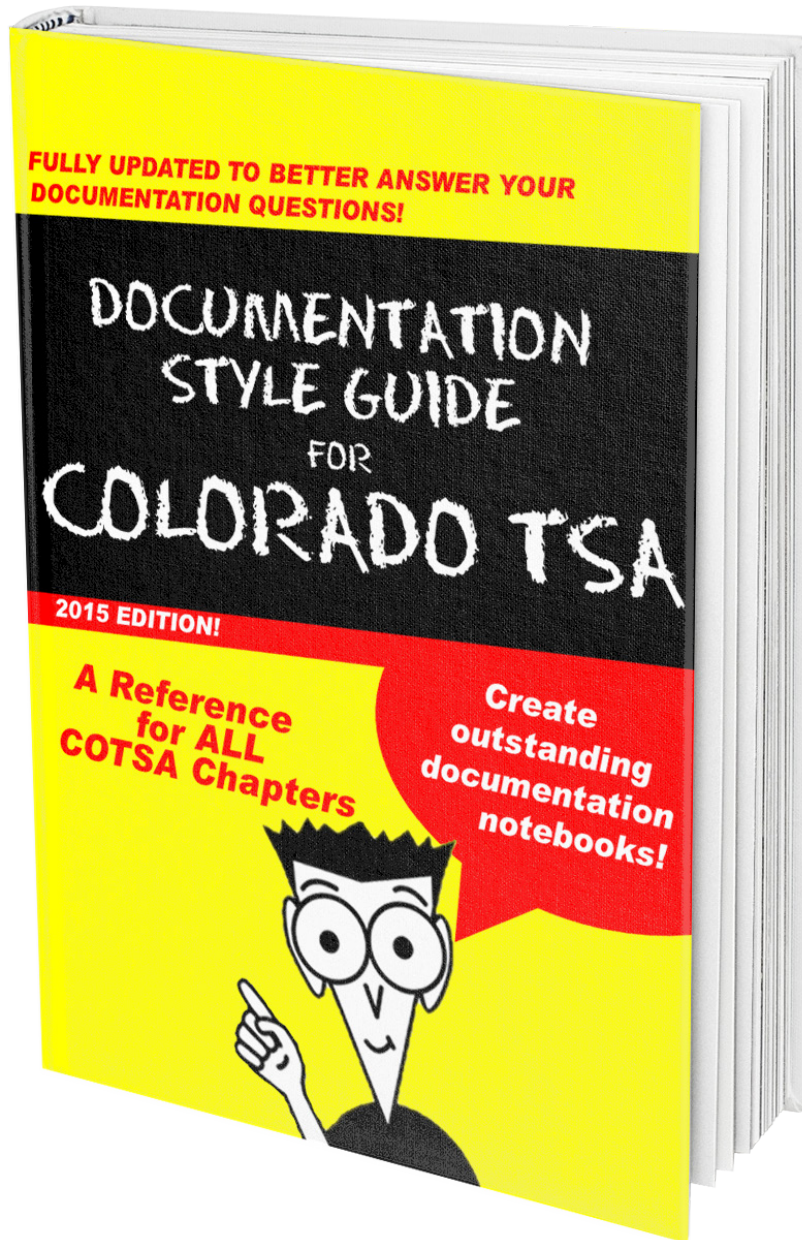

Do you need help with your documentation for your project? Look no further!

The COTSA Documentation Style Guide on the following pages has been developed to help all TSA members put together outstanding documentation portfolios for their projects.

The guide is in its entirety on the next few pages! Print these out and keep them handy as you prepare your projects for competition!

IMPORTANT CHANGE: All entries require documentation materials (comprising a “portfolio”), now require that a clear front report cover is to be used to hold all the documentation together. Please visit http://www.staples.com/Oxford-Clear-Front-Report-Covers/product_SS1003226 for a sample report cover.

For early submission events, portfolios must be in PDF format and uploaded using the COTSA Submission site at: <http://goo.gl/hwsZ-vG>. However, students should also plan on bringing a hard copy of the documentation portfolio to the state conference in the event the contest entry advances to a finalist round.



Style Guide Introduction

In today's technological world, communication takes a variety of forms – one of which is writing. Any successful technological endeavor will have with it a set of documents that detail its inception, development and evaluation. The projects for TSA are no different!

Most competitive events require the creation of a documentation portfolio. Each event that does require a portfolio will require that certain specific items be included – for example, some projects may require drawings or photographs while others won't; some may require photo release forms while others may require work logs. Still, despite their differences, they do have a lot in common. It is the intent of this guide to help you create high quality documentation portfolios for your projects – regardless of the competitive event – for both state AND national conference submission.

PLEASE REVIEW AND FOLLOW THIS GUIDE WHEN PREPARING YOUR DOCUMENTATION PORTFOLIOS!

Before we begin, it is critical that you are reminded to follow each specific contest's rules and regulations closely! Don't rely on this guide alone to create the documentation! This guide is not designed to tell you what to include for each contest, but rather, help you format and create professional looking portfolio for your project.

General Guidelines

When preparing any documentation portfolio, the first thing you need to know is that it must be typed. Handwritten documentation is NOT acceptable. Yes, there will be items in the documentation that will be required to be handwritten or hand drawn, but those items are few and far between. In general, it's a good rule of thumb to only submit documentation that has been word processed. There are a few reasons for this:

- You have spell/grammar check. While it's not always accurate and will not pick up on all your mistakes (like using "THEIR" instead of "THERE"), at least you have the opportunity to eliminate the bulk of spelling and grammar mistakes.
- It's easier to read. The judges are usually "old folks" and they have a hard time reading chicken scratch. If you want to win, you'll need to make sure your documents are legible!
- You can edit a computer document. What happens if, in the process of proofreading your documentation, you discover you need to add in a chart or graph in the middle of text, or correct a spelling mistake in the critical paragraph that sums up all your work? If you have a handwritten document, that means either a complete re-write or a messy addition. Storing your document on your computer means you can go back and edit the document until it's just right to print!
- In most cases, documentation that is hand-written, unless otherwise specified, will be assessed penalty points or disqualified. The assessment of penalty points could very well take an otherwise-stellar project out of medal contention. And after all the work you put into a project, it would be a shame to see it penalized because of handwritten documentation!

Specific Guidelines

Do you need documentation?

The first thing you need to figure out is if you even need to prepare documentation portfolio at all. The answer is probably yes, but there are a few events (dragster, for example) that do not require a full portfolio. If your project does not require a documentation portfolio, make sure you turn in only what the contest guidelines call for and nothing more...and nothing less. If you turn in more than is required, there is a good chance that all the additional material will NOT be considered by the judges - or worse, assessed penalty points because it is “extra material.” If you turn in less than is required, at best you could receive a penalty and at worst, your project could be disqualified. In any case, it’s a good idea to read over the rules (**ALL THE RULES**) for an event before you begin and assemble whatever materials you’ll need to complete the project as you go – including a portfolio!

DO NOT wait until the last minute to assemble your documentation. Start the portfolio when you start your project so you can accurately record things as you do them (like work logs) rather than trying to re-create them later!

REGULATIONS

Architectural Illustration

Read the General Rules and Regulations in the front of this guide for information that applies to all of TSA's competitive events.

A model is neither a "miniature building," nor a mere illustration of a design concept. It serves as an assessment tool for the design. Too much detail can obscure important qualities, and not enough detail may generate an overly vague impression.

REGULATIONS

A. The architectural model must be placed on a site board no larger than 14" square.

B. A documentation notebook is required and must be submitted with the display. A standard three (3) ring binder, with a clear front sleeve for a cover page, is required. The cover page must include the event title, the conference city and state, and the year. The inside of the binder must include the following (single-sided, 8 1/2" x 11" pages, in the order):

1. Title page with the event title, the conference city and state, and the year; one (1) page
2. Table of contents; pages as needed
3. A description of how the team interpreted the design challenge and an explanation of the style and merits of the team's design concepts; one (1) page
4. Demolition plan for the existing structure; maximum of two (2) pages
5. List and describe how each of the following construction systems (any and all that apply) have been incorporated and applied to the team's solution: building codes, building permits, construction methods and materials, electrical wiring, plumbing, HVAC, and site requirements; maximum of six (6) pages
6. ALEED assessment for the project, according to the USGBC standards for green building; one (1) or more pages
7. A schedule of finish materials for all exterior and interior surfaces of the architectural design (this is not a list of the model construction materials); one (1) page
8. A reproduction copy of original hand drawings and printer/plotter-generated copies of CAD drawings for the following required drawings (each drawing to be submitted on maximum drawing sheet cut size 8 1/2" x 11") with

In each competitive event, look in the REGULATIONS SECTION. There, you'll see EXACTLY what is required, including any requirements for a notebook.



The Rules? What are the rules? Where do I find them?

The rules for all of the competitive events are located in the Competitive Events guides, of which there are two:

- National TSA Competitive Events Guide (there is one for the high school and one for the middle school; use the right one for your level).
- Colorado TSA State Competitive Events Guide (this one contains all the rules for both the middle and high school events that are only offered at the state level).

The competitive events are listed alphabetically in each of the books and are broken into several sections:

- **National Competitive Events Guide**
 - Overview – A brief summary of the event.
 - Purpose – This tells you the goal of the event – what you are supposed to learn/do.
 - Eligibility – This tells you how many individuals/teams from your chapter/state can compete in a contest.
 - Time Limits: This tells you how long certain portions of the contest will take.
 - Attire – This section tells you what the uniform requirements are for the contest. This is what you must wear to compete in the event at the state or national level. If you are not wearing appropriate attire, you will be assessed a rules violation or disqualified.
 - Procedure – This section tells you how the contest will work.
 - Regulation – These are the “rules” for the event. It explains in detail what you should include in your project – a display, a documentation portfolio, a model, etc.
 - Evaluation – This tells you how the project will be graded. Use this with the rubric to see exactly what the judges will be looking for.
 - Notes – Specific notes for you that relate to the project.
- **COTSA State Competitive Events Guide**
 - Purpose – This tells you the goal of the event – what you are supposed to learn/do.
 - Eligibility – This tells you how many individuals/teams from your chapter can compete in a contest.
 - Specific Regulations - These are the “rules” for the event. It explains in detail what you should include in your project – a display, a documentation portfolio, a model, etc.
 - Procedure – This section tells you how the contest will work.
 - Evaluation – This tells you how the project will be graded. Use this with the rubric to see exactly what the judges will be looking for.

When do you need to start the documentation portfolio?

You need to start building the documentation portfolio as you begin work on your project. Most contests will require you to keep a work log or include preliminary drawings you create as you work through the process. Do not wait until you are finished with the project to create your portfolio! If you do, you're liable to leave out crucial information that could mean the difference between winning a medal or not.

Where do you look to see if you need a portfolio?

Look at the rules for your competitive event. Find the REGULATIONS or SPECIFIC REGULATIONS section. Here you will see EXACTLY what is required for the contest, including information on the documentation portfolio. Below is an example from the High School National Competitive Events Guide showing the Regulations Section.

REGULATIONS

Architectural Illustration

Read the General Rules and Regulations in the front of this guide for information that applies to all of TSA's competitive events.

A model is neither a "miniature building," nor a mere illustration of a design concept. It serves as an assessment tool for the design. Too much detail can obscure important qualities, and not enough detail may generate an overly vague impression.

REGULATIONS

A. The architectural model must be placed on a site board no larger than 24" square.

B. A documentation notebook is required and must be submitted with the display. A standard three (3) ring binder, with a clear front sleeve for a cover page, is required. The cover page must include the event title, the conference city and state, and the year. The inside of the binder must include the following single-sided, 8 1/2" x 11" pages, in this order:

1. Title page with the event title, the conference city and state, and the year; one (1) page
2. Table of contents; pages as needed
3. A description of how the team interpreted the design challenge and an explanation of the style and merits of the team's design concepts; one (1) page
4. Competitive plan for the existing structure; maximum of two (2) pages
5. List and describe how each of the following construction systems (any and all that apply) have been incorporated and applied to the team's solution: building codes, building permits, construction methods and materials, electrical wiring, plumbing, HVAC, and site requirements; maximum of six (6) pages
6. LEED assessment for the project, according to the USGBC standards for green building; one (1) or more pages
7. A schedule of finish materials for all exterior and interior surfaces of the architectural design (this is not a list of the model construction materials); one (1) page
8. A reproduction copy of original hand drawings and printer/plotter-generated copies of CAD drawings for the following required drawings (each drawing to be submitted on maximum drawing sheet cut size 36" (9" x 12") with

In each competitive event, look in the REGULATIONS SECTION. There, you'll see EXACTLY what is required, including any requirements for a notebook.

The Portfolio

- For all entries that require documentation materials (comprising a “portfolio”) all pages should be secured in a clear front report cover. An example of the cover is shown below, or you can visit http://www.staples.com/Oxford-Clear-Front-Report-Covers/product_SS1003226 for a sample report cover.
- For early submission events, portfolios must be in PDF format and uploaded via the COTSA State Conference Early Submission Entry Form at: <http://goo.gl/r0zz1F> . You will need to enter your contestant ID# and a contact email address.
- **DO NOT use 3-ring binders**; while they may have been acceptable in the past, they will no longer be acceptable for submissions at the state and national conferences.
- You may use page protectors. Using them may prevent pages from being accidentally ripped or torn out or worse yet, lost.
- Do not double-side the pages in the protectors unless it specifically says to do so in the competitive event rules.





The Documentation

Ok, now that you know what you should have to put your documentation into, you can dive into the meat of the project...the documentation. Your documentation has the ability to either make or break your project, so you should spend just as much time on it as you do the rest of the project, if not more!!

Remember that all the documentation in your portfolio should be word processed. DO NOT include handwritten documentation unless it is specifically called for in the event guidelines. Some events may require you to submit notes and sketches – those pieces of documentation are acceptable if handwritten.. However, the remainder of the documentation must be typed on a computer and printed on an ink jet or laser printer.

The documentation should be printed on 8.5” x 11” paper unless otherwise stated by your event guidelines.

The documentation should be printed single-sided unless otherwise stated by your event guidelines.

All entries must be in English. Unless otherwise specified, no identifying information -- other than an ID# -- is to be included on an entry. Exceptions to this rule are those events that require content aligned with a school or community (Children’s Stories, Construction Challenge and Community Service Video).

Remember to proofread your document. Have several people proofread it and check for grammar and spelling before you submit it. The spell-check/grammar-check in your computer is good, but it’s not perfect, so don’t rely solely on it. The computer may not pick up on the wrong usage of words such as “HEAR” vs. “HERE” or “THEIR” vs. “THERE”. The misuse of words in your documentation could cost you points and that could translate into a lost medal or trophy!

Here the specifications you should use in creating your documentation:

Font Size:

- Use only 11 or 12 point type. Do not shrink your type to fit on a page; and conversely, do not increase the size of your type to fill a page. Instead, use concise language to get your text to fit! Don’t be afraid to edit!
- Do not mix and match type sizes in your document. Keep all text the same size unless specifically instructed to do so for your competition.



Font Style:

- Throughout your documentation, be consistent in the use of fonts and typefaces, both in style and in size. Don't mix and match fonts. It's visually unappealing and makes the portfolio look unprofessional. Pick ONE typeface and stick with it throughout all of the documentation.
- Use a standard type font such as Times New Roman or Arial. Yes, it may be "boring," but if you have to do some last minute work on a computer that isn't yours, they may not have that fancy typeface you're using. You are more likely going to find Arial or Times New Roman than anything else (and that will help prevent you from reformatting the entire document!). Besides, using one of these two fonts will make your documentation easier for the judges to read.
- Do not use Word Art! Just because you can, doesn't mean you should. For headings, subheadings, and titles, use a bolded, bolded/italic version of the same font you used for the body text.

Character Spacing:

- Put only one (1) space after punctuation ending a sentence. Thanks to computers handling spacing for you, you only need one. And stay consistent in the use of spaces in the document.
- Use one (1) space after a semicolon (;) comma (,) or colon (:).
- Use one space between any state abbreviation and zip code.

Line Spacing:

- Unless otherwise specified in a competitive event's guidelines, all text should be single-spaced with a double-space put in between paragraphs.
- When using bulleted lists, single space individual items; double space between numbered items just like the items in this bulleted list).

Margins:

- In general, unless otherwise stated in the competitive event guidelines, all margins should be 1" (one inch).
- Do not shrink or stretch the margins. Don't increase the size of your margins to help stretch the length of your document, and don't decrease them to shorten a lengthy document. Fudging the margins makes the document look unprofessional and messy. It is far better to edit the text to fit the space instead.



Page Numbers:

- Include page numbers. This will help judges easily find information in your documentation.
- Page numbers should be in the same font size and style as used throughout the documentation.
- Page numbers should be 0.5" from the bottom of the page at the right margin starting on page 2.

Below is an example of what a page of text in a documentation portfolio should look like:

The diagram illustrates a page layout with the following elements:

- Text Sample:** A box at the top right containing the text "Text Sample".
- 1" margin:** Indicated by red arrows on the top, bottom, left, and right sides of the page content.
- Heading:** A red arrow points to the word "Heading" at the top left.
- Type is all the same font and the same size:** A red arrow points to the first paragraph of text.
- Text is single spaced with a double space between paragraphs:** A red arrow points to the space between the first and second paragraphs.
- For bulleted lists, single space individual items; double space between numbered items:** A red arrow points to the first item of a numbered list.
- Page Number:** The number "2" is located at the bottom right of the page.
- 1/2" margin:** A red arrow points to the bottom right corner, indicating the distance from the page number to the bottom edge.

What's Inside the Documentation

Here's what you should include in your documentation portfolio, along with any specific items the event guidelines call for:

The Cover Page:

Every portfolio should have a cover page. This will help a) make sure your project is placed in the right area to be judged; b) aid the judges when they are evaluating your notebook/project.

The cover should be blank, except for:

- The Event Title
- The Conference city and state (this will need to be changed if the project progresses from the state conference to the national conference)
- The Year
- **DO NOT PUT YOUR NAME OR ANY OTHER IDENTIFYING INFORMATION.** For state, including your ID number or TEAM ID number is acceptable. For nationals, do not include any identification whatsoever. When you turn in your project at nationals, you will receive a sticker with an ID number (one that is completely different from your state conference ID number) to put on it.

That's it – plain and simple. **DO NOT** include any art, graphics, sketches, logos, or other information - not even the official TSA logo! Yes, it may be dull and boring, and it may not look all that attractive, but each competitive event calls for a simple cover to identify the portfolio and the event to which it belongs. That's all. Nothing more. If you do not provide the correct cover page, the entry may not be placed in the proper area for judging or it may not be judged at all!

At the right is an example of what a cover page should look like:

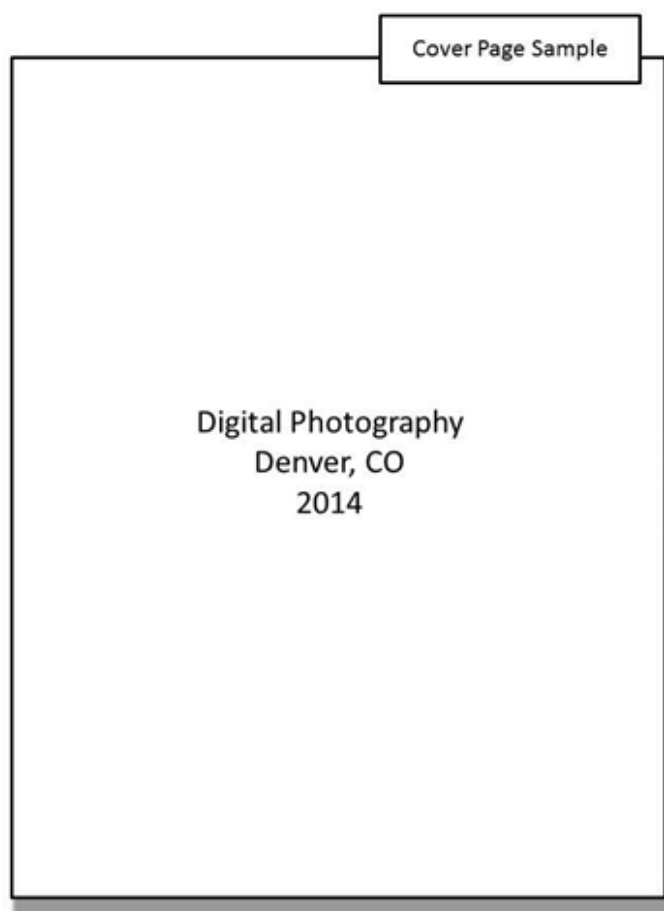



The Title Page:

The title page is different from the Cover Page. The title page is the start of the written documentation and appears as the FIRST page, INSIDE the portfolio after the cover page. Here are the specifications for a Title Page:

- The Title Page is one (1) page in length and should not include any graphics (including Word art), logos, sketches or other identifying information.
- The Title Page should include:
 - The Event Title
 - The Conference City and State
 - The Year of the Conference
 - The Team/Chapter ID Number – This number should have been provided to your chapter advisor after registration for the state conference. This number will change if the project progresses from the state conference to the national conference. Do not put your name, school name, or any other identifying information other than your ID number. When submitting the entry at the national conference, you will need to remove the state ID number. At the national conference, when turning in an entry, you will be supplied with a sticker to affix to your entry to identify it as your own.

At the right is an example of what a Title Page should look like:

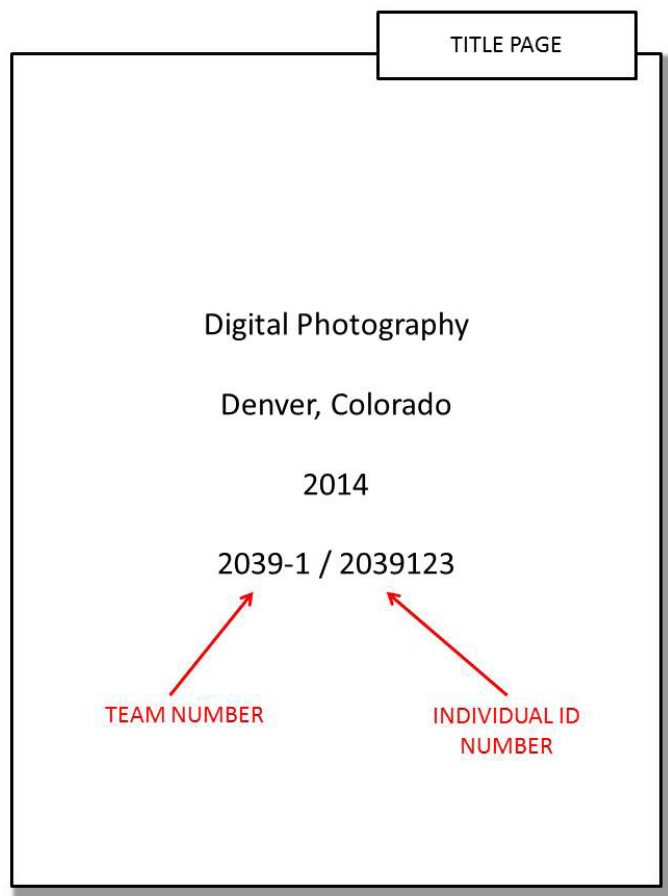

Table of Contents:

Most documentation notebooks will require a Table of Contents. Here are the specifications for the Table of Contents:

- The Table of Contents can be as many pages as needed.
- The Table of Contents heading should be centered at the top of the page, followed by a double-space.
- The items in the table of contents should include all the items called for in the event's guidelines and they should be in the same order as called for in the guidelines.
- The names of the items in the table of contents should be flush left.
- The page numbers should be right-aligned with leader lines.

An example of a table of contents is shown below.

TABLE OF CONTENTS

TABLE OF CONTENTS

Introduction.....	1
Investigation	
Identification of the Problem.....	2
Design Brief.....	3
Design Specification.....	5
Design	
Design Process.....	7
Production Plan.....	9
Solution Creation	
Tools, Materials & Processes.....	11
Work Log.....	12
Evaluation	
Evaluation of Solution.....	13
Evaluation of the Production Plan.....	15
Self Evaluation.....	17
Suggested improvements.....	19
References.....	20



The items in the table of contents should be listed exactly as they appear in the event guidelines. They should be flush left.



There should be a dot leader to direct the reader to the page number.



The page numbers should be flush right against the margin.

All type should be the same size and the same font as the rest of the document. No artwork, logos or other graphics should be included on this page. KEEP IT SIMPLE!



Tables:

Tables are useful in showing data and you should use them where appropriate. However, unless they are formatted neatly and consistently, the data becomes lost or unusable. Here are the formatting guidelines for tables:

- Use bold type for titles and column headings
- Column headings should be centered over column.
- Tables using one- and two-line column headings should be aligned at the center of the cell.
- Unless specifically required by your event’s guidelines, gridlines should be used.
- Include the dollar sign (\$) when showing dollar amounts in columns.
- All columns containing numbers should be right-aligned or decimal aligned.
- All columns containing text should be left aligned (with the exception of column headings).
- The body of the table should be single-spaced.
- Tables should be centered on the page horizontally unless otherwise indicated.

At the right is an example of how a table should look:

TABLES

Use bold type for titles and column headings. Column headings should be centered over the columns.

Tables using one- and two-line column headings should be aligned at the center of the cell.

Unless specifically required by your event’s guidelines, gridlines should be used.

Example of a Table

Column Heading	Column Heading	Column Heading
Text goes here. It is flush left.	Text goes here	\$100.00
The table is centered on the page. Note that text can take up more than one line.	Text can also go here.	\$200.00
Use gridlines for any table you create.	And so is this.	\$300.00
Make sure you align your decimal places.	And this is, too!	\$400.00

All columns containing text should be left aligned.

The body of the table should be single-spaced.

Include the dollar sign (\$) when showing dollar amounts in columns. All columns containing numbers should be right aligned or decimal aligned.

Tables should be centered on the page horizontally unless otherwise indicated.

Resumes:

Some contests require you to turn in a resume. Here are tips to create a clear, readable resume that can be read by optical character recognition scanners some employers use. Even though you won't have your resume scanned by a machine in TSA competition, it's still a good idea to keep these pointers in mind when creating a resume:

- Use a single, non-decorative font (Arial or Times New Roman are the most common)
- Be sparing in your use of boldface, italics and underlining.
- When it comes to bullets, do not use round hollow bullets as they can be misread by scanners some employers use. They could be misread as the lowercase letter "o" or the digit zero. Instead, use round, solid bullets.
- Avoid using any shading or boxes on your resume.
- Be careful that you do not have letters that touch each other. Scanners have trouble interpreting text when characters touch or overlap.
- Do not use ampersands (&) percent signs (%) or foreign characters as the scanner may not read them properly.
- Try not to use lines or other graphic elements on your resumes. Scanners have a tough time translating them.
- Do not use a multi-column format. Scanners read text left to right and cannot distinguish between columns like the human eye can.
- Begin each line at the left margin and do not justify the right margin.

On the next page is a sample of how a resume might look. You do not have to use the exact format of the sample presented here; it's only there to help get you started. There are many other examples of resumes available on the Internet or through resources available through your teacher.

Sample Resume

Johanna S. Bach

123 Main Street
Anytown, US 12345
(555) 555-5555

Objective:
A very impressive and convincing objective statement should be written to enrich worth of a resume. Resume objective can be two to three lines in length. Be concise and mention the name of the position you are applying for.

Employment History:
Company Name, City, State – Month/Year to Month/Year
• Bullet points of job duties go here.
• Bullet points of job duties go here.
• Bullet points of job duties go here.
Company Name, City, State – Month/Year to Month/Year
• Bullet points of job duties go here.
• Bullet points of job duties go here.
• Bullet points of job duties go here.
Company Name, City, State – Month/Year to Month/Year
• Bullet points of job duties go here.
• Bullet points of job duties go here.
• Bullet points of job duties go here.

Skills:
• Job related skills will be written here as bullets.
• Job related skills will be written here as bullets.
• Job related skills will be written here as bullets.

Education:
• Degree/Diploma, School, City, State, Year of Degree/Diploma
• Degree/Diploma, School, City, State, Year of Degree/Diploma
• Degree/Diploma, School, City, State, Year of Degree/Diploma

References:
Available Upon Request

Be careful! Don't put your real or identifying information on a resume unless the contest specifically asks for it!

Use common subject headings followed by a colon.

For employment date ranges, be specific for each experience.

List skills that directly relate to the job you are applying for.

Make sure you include all relevant educational experiences, including internships.

Prepare a list of references (at least 3 and include all contact info) ahead of time just in case the interviewer asks for them.



References/Sources/Works Cited:

You will be required to cite where you got information you used in the creation of your projects. If you think you can just cut/copy/paste from the Internet – think again. That’s plagiarism and it will get you disqualified faster than anything! Yes, take the information...read it...digest it...analyze it... even quote it...but don’t forget to cite where you got it! (And no, www.google.com is not a reference. Google is a search engine. It’s the website Google takes you to that’s the source - and even then, it may not be the original one!)

In TSA documentation, you must use MLA format (MLA stands for Modern Language Association). If you want to really get into the MLA format, you can visit this website: www.mla.org/style. However, below is a quick reference checklist for you. The checklist, provided courtesy of FBLA-PBL, shows how each of the various sources should be cited in a References section in your documentation. (FBLA-PBL Format Guide. Reston, VA. FBLA-PBL, 2014).

REFERENCES – MLA STYLE

- **Sample Book Reference:**

Bohlman, Herbert M., and Mary Jane Dundas. *The Legal, Ethical and International Environment of Business*. 5th ed. Cincinnati, OH: Penguin, 1987. Print.

- **Sample Book Reference without Author:**

The Economist, Princeton Press: Princeton, 1997. Print.

- **Sample Magazine Reference:**

Cohen, Stephen S., and J. Bradford DeLong. “Shaken and Stirred.” *Atlantic Monthly* Jan.-Feb. 2005: 112. Print.

- **Sample Magazine Reference without Author:**

“Coca-Cola Paid CEO \$32 Million U.S. in 2007.” *Toronto Star* 4 Mar. 2008: B2.

- **Sample Internet Reference:**

Thomason, Larisa. HTML Tip: Why Valid Code Matters. *Webmaster Tips Newsletter*. Dec. 2003. NetMechanic. 6 Jan. 2008 <www.netmechanic.com/news/vol6/html_no20.htm>.

- **Sample Encyclopedia:**

Nazi Party. *New Encyclopedia Britannica*. New York: Somerset, 1997 ed.

Continued on next page



Continued from previous page

- **Sample Interview Reference:**

Chirac, Jacques. Interview by John Smith. Time 16 Feb. 2003. 10 Oct. 2005 www.time.com/time/europe/magazine/2003/0224/cover/interview.html

- **Sample Booklet/Pamphlet Reference:**

Diabetes Care: Blood Glucose Monitoring. Burnaby, BC: LifeScan Canada, 1997.

- **Sample DVD Reference:**

Encarta 2004 Reference Library. CD-ROM. Microsoft, 2003.

- **Sample Radio/Television Reference:**

"New York Museum Celebrates Life of Einstein." By Martha Graybow. Reuters, New York. WBFO, Buffalo. 13 Nov. 2002.

- **Sample Government Pubs Reference:**

United States. National Council on Disability. Carrying on the Good Fight Summary Paper from Think Tank 2000- Advancing the Civil and Human Rights of People with Disabilities from Diverse Cultures. Washington: GPO, 2000





Colorado Technology Student Association

2016-2017 State Competitive Events





Catapult Design

OPEN TO HIGH SCHOOL STUDENTS

I. OVERVIEW

Participants design and produce a working catapult, within specified guidelines, that is adjustable and propels hollow plastic practice golf balls (weighing about 14.5 grams each) at a scoring target between 15' and 25' away.

II. ELIGIBILITY

Participants are limited to three (3) teams of up to four (4) individuals per state.

III. TIME LIMITS

- A. Entries must be started and completed during the current school year.
- B. The catapult and design portfolio must be picked up at the designated time at the conclusion of the event.

IV. PROCEDURE

- A. Participants check in their entries at the time and place stated in the conference program.
- B. Catapults are inspected by evaluators to determine among other things, safety. Catapults that meet all Go/No-Go regulations will be approved for the performance stage of the event. Any unsafe devices will be disqualified. (Unsafe catapults include those with parts that detach during operation or those with a dangerous rotation or throwing motion, either of which could cause harm or damage.) Judges will make a final determination about the operational safety of a catapult.
- C. If an entry's catapult is approved for the performance stage of the event, the entry's design portfolio will be evaluated.
- D. A time sheet will be provided for sign up at check-in.
- E. Students must be present for the performance stage of the event.
- F. Teams will receive a bucket of three (3)-dozen hollow plastic practice golf balls (each weighing approximately 14.5 grams) for the performance stage.
- G. Students must bring and wear safety glasses for this stage of the event.
- H. One (1) team member will use a 25' tape measure for measuring and recording the distance from the catapult to the target as it is set for the given test day.
- I. The team will be given five (5) minutes to adjust its catapult for accuracy to that distance.



-
- J. Teams will position their catapult on the “firing line” and wait for the command to fire.
 - K. Multiple teams with different colored hollow plastic practice golf balls will launch at the same time.
 - L. When teams receive their bucket and the fire command is given, they will have one (1) minute to launch as many hollow plastic practice golf balls as possible, one at a time, to accumulate as many points as possible in the net. Each team must cease firing at one (1) minute. No shots made after time has been called will count.
 - M. The center of the scoring net will be approximately 15' to 25' from the launching area; students should use their tape measure to determine the distance to the center of the target in order to adjust their catapult for accuracy to that distance. The scoring net will consist of a golf chipping target and three (3) color-coded scoring sections. The red center target is 10” in diameter, the green is 25” in diameter, and the blue target is 40” in diameter.
 - N. Scoring is as follows: red target, 5 points; green target, 2 points; blue target, 1 point.
 - O. Hollow plastic practice golf balls must enter the target on the fly and be fully in the scoring net to score points. No points will be earned for bounced-in or half-in/half-out hollow plastic practice golf balls.
 - P. Ties will be broken as follows: 1) the team with the highest score and least amount of hollow plastic practice golf balls in the target, and/or 2) the team with the shortest time recorded to score the most points.
 - Q. Final ranking will be determined from points earned 1) for the design portfolio and 2) the catapult’s performance.
 - R. Lack of catapult compliance may result in disqualification.
 - S. Team members must collect all hollow plastic practice golf balls once judges complete recording points and before leaving the event area.

It is essential that students and advisors routinely check the TSA website (www.tsaweb.org) for updated information about TSA general rules and competitive event guidelines. This information can be found on the website under Competitions/Competition Updates. When students participate in any TSA competitive event, they are responsible for knowing of all updates, changes, and clarifications related to that event.



V. REGULATIONS

- A. Each team must record its research and development process—from inception through testing and modification—to the performance stage for competition. This documentation should be submitted as a design portfolio, complete with sketches, pictures, and descriptions of the processes, successes, and failures related to the designed catapult.
- B. Documentation materials (comprising the “design portfolio”) are required and should be secured in a clear front report cover. The report cover must include the following single-sided, 8½” x 11” pages, in this order:
 - Title page with the event title, the conference city and state, the year, and the team/chapter ID number; one (1) page
 - Table of contents
 - Materials list; one (1) page
 - Details of the research and inspiration to help determine the design for a catapult
 - A design log (that includes testing and adjustment notes) from the start date to the present; pages as needed
 - Sketches and pictures of the design process; pages as needed
- C. Participants must bring and wear safety goggles during the performance stage of the event.
- D. Teams must provide their own tape measure (at least 25’ length).
- E. The catapult may be no larger than 2’ tall x 2’ long x 1.5’ wide.
- F. The base of the catapult should accommodate the provided ballast. The ballast will be one (1) 50-pound bag of playground sand, provided by TSA on site.
- G. The catapult must operate completely within the given area; the launch arm may extend beyond the front of the catapult only while launching.
- H. The catapult may have any type of spring mechanism to power the arm, but all parts must be contained within the 2’ tall x 2’ long x 1.5’ wide maximum footprint prior to launch.
- I. The catapult’s total weight must not exceed fifteen (15) pounds.
- J. All parts of the catapult must initiate behind the launch line, but parts may extend over the line during and after the last launch.
- K. The catapult cannot have wheels.
- L. The catapult must be made entirely from PVC pipe, with the exception of the launch mechanism, firing mechanism, fasteners, and safety items. These items may be wood or metal and must be constructed in a safe way, so as not to damage the device, the testing area, or cause harm to others.



-
- M. The following may not be used:
- Glass
 - Flammable, corrosive, or explosive materials
 - Compounds that produce odors or gases
- N. The catapult must have at least a five (5)-foot pull cord to launch from a safe distance.
- O. When the catapult is on display or not in the performance stage, it must be fully disabled and unable to be readied for firing.
- P. Catapult Go or No-Go Compliance - A catapult that receives a “No” answer to any of the requirements below will not advance to the performance stage of the event.
- Does the team have safety goggles? (Yes/No)
 - Can the catapult be weighed down with a sand bag? (Yes/No)
 - Is the catapult within the size specifications? (Yes/No)
 - Is the catapult built with the correct materials? (Yes/No)
 - Does the catapult launch with a pull cord? (Yes/No)
 - Does the catapult have a safe launching mechanism? (Yes/No)
 - Is the catapult safe to operate? (Yes/No)

VI. EVALUATION

Evaluation is based on the portfolio and points earned for the catapult’s performance. Please refer to the official rating form for more information.



Participant/Team ID# _____

CATAPULT DESIGN			
2016 OFFICIAL RATING FORM		HIGH SCHOOL	
A catapult that is marked No-Go for any of the requirements below will not advance to the performance stage of the event.			
Team members must have safety goggles	Go	No-Go	
The catapult can be weighed down with a sand bag.	Go	No-Go	
The catapult is the correct size	Go	No-Go	
The catapult is built with the correct materials	Go	No-Go	
The catapult launches with a pull cord.	Go	No-Go	
The catapult has a safe launching mechanism	Go	No-Go	
The catapult is safe to operate	Go	No-Go	
Design Portfolio			
CRITERIA	Minimal Performance 1-4 points	Adequate Performance 5-8 points	Exemplary Performance 9-10 points
Portfolio (X1)	Portfolio is unorganized and/or missing three or more components.	Portfolio has most components, and it is somewhat organized.	One or no components are missing in the portfolio, and content and organization are clear.
Research (X1)	There is little evidence of research to help determine the design for a catapult.	Some research is present to help determine the design for a catapult.	Ample and thorough research to help determine the design for a catapult is evident.
Design log (X2)	Design log lacks information about the design process (including testing and adjustments) for the final catapult.	Design log adequately conveys the design process (including testing and adjustment) for the final catapult.	Design log provides thorough and quality information about the design process (including testing and adjustments) for the final catapult.
Sketches and pictures (X1)	Sketches and/or pictures do not help illustrate the design process.	Sketches and/or pictures are appropriate and help illustrate the design process.	Sketches and/or pictures are of excellent quality and thoroughly illustrate the design process.
SUBTOTAL (50 points)			
Catapult Performance			
# Hollow Plastic Practice Golf Balls		Score	
Red target - 5 points each			
Green target - 2 points each			
Blue target - 1 point each			
PERFORMANCE SUBTOTAL			

Record scores in the column spaces below.

Rules violations (a deduction of 20% of the total possible points) must be initiated by the evaluator, coordinator and manager of the event. Record the deduction in the space to the right.

Indicate the rule violated: _____

(To arrive at the TOTAL score, add any subtotals and subtract rules violation points, as necessary.) **TOTAL SCORE**

Comments:

I certify these results to be true and accurate to the best of my knowledge.

Evaluator: _____ Printed name: _____ Signature: _____



Crash Test

OPEN TO MIDDLE SCHOOL STUDENTS

I. PURPOSE

This event is designed to stimulate elementary students' interest in TSA by encouraging middle school TSA members to share their love and interest in technology. For this contest, one elementary student (grades 1-5 or 6 - SEE ELIGIBILITY SECTION BELOW) will work with a middle school student to design and build a "crash test car" that will be tested in multiple head-on and rear-end collisions. The survivability of the passenger, a regular raw egg, will be a determining factor in the car's success.

II. ELIGIBILITY FOR ENTRY

This event is open to Middle School TSA Chapters. Entrants are limited to TEN (10) teams of two (2) students per chapter. Each team **MUST** have 1 elementary student, and 1 middle school student. Students in 6th grade can be considered elementary students **ONLY IF** 6th grade is part of the elementary school in which they are currently enrolled. Students in sixth grade who are part of a K-8 or K-12 school would be considered middle school students. Contact the state advisor if there are any questions regarding eligibility.

III. SPECIFIC REGULATIONS

- A. The theme for 2016-17 will be: Emergency Vehicle.
- B. All entries must be designed and constructed before the conference.
- C. Vehicles must be turned into the event coordinator at the beginning of the conference to be displayed. Students may not pick up their vehicles until the end of the conference.
- D. The crash test vehicle:
 - Must comply with the current year's published theme.
 - Must have seating capacity for at least TWO passengers (although only one egg will be used for testing purposes). Seating should be able to accommodate not only the egg, but the "body bag" (Ziploc™ snack size bag) as well.
 - Cannot use pre-made containers for the passenger compartment (for example, Rubbermaid™, Tupperware™, Gladware™ or similar containers). However, portions of the passenger compartment may pre-made (for example, a single cup from an egg carton, or a plastic steering wheel from a model car kit).
 - The safety systems and the vehicle body should not have metal components
 - Must have a windshield through which the driver can be clearly seen.
 - Must have at least one clearly identifiable safety system for occupant protection.
 - Must have both front and rear bumpers.
 - Must have a steering wheel within reach of the driver.
 - Must have a reusable way to get the driver in and out of the vehicle after each impact. The egg will be checked for survivability after every crash.



- Must have a flat bottom with four 1.5" strips of Velcro (the soft side) firmly attached. This will keep the vehicle on the testing sled.
 - Should NOT have any wheels. The wheels are provided in the form of a testing sled. (See attached schematic for the testing sled specifications.)
 - Must be between 3"-4" in width
 - Must be between 7"-12" in length
 - Has no restriction on height.
- E. No commercially produced kits are allowed. The car must be primarily designed and built by the elementary student with guidance from the middle school student.
- F. The vehicle will be placed on a testing sled which will serve as the wheels for the vehicle. A schematic of the sled is provided with these regulations.
- G. The ramp is made from a standard 1" x 10" x 3/4", with 1" x 2" x 3/4" boards as side rails. The end block is a composite hardwood block 9" wide, 8" high and 6-1/2" thick. It is reinforced on the sides with 3/4" solid wood. The guard rails will assist the vehicle down the ramp, but will NOT prevent the vehicle from leaving the track. A schematic of the ramp is included with these regulations.
- H. A drawing of the vehicle done by the elementary student must accompany the vehicle. It should be as accurate to the final model as possible.
- I. The elementary student should be the primary lead in the design and construction of the vehicle.
- J. The middle school student must present a portfolio documenting the project. The portfolio should include:
- Photos of the project
 - An essay describing the project and each person's part in it
 - A time log documenting the time spent with the elementary student on the project.

IV. PROCEDURE

- A. Participants will turn in their vehicles and design briefs to the display area at the beginning of the conference.
- B. At the time of testing, each vehicle will be given a single, raw egg and a "body bag" (a single snack-sized Ziploc™ bag) to contain any potential egg innards should the shell crack during testing.
- C. The sled, with the car attached, will be rolled down the testing ramp. At the end of the ramp will be a barrier (which may or may not have protrusions) into which the car will crash.
- D. After the car has impacted the barrier, the egg must be removed to check for cracks. If the egg is broken, the crash was unsuccessful and testing will be stopped. If the egg remains unbroken, testing will continue.



-
- E. The starting edge of the ramp will begin at 4' from the floor. After each successful test, the starting edge of the ramp will be raised 2', until the ramp is near vertical. If the vertical test is successful, the ramp will be lowered back to the 4' level and the car will be repositioned BACKWARDS on the sled and the tests will be repeated. If the backwards test is successful, the ramp will be lowered back to the 4' level and the car will be repositioned forwards on the sled and the tests will be repeated with unknown "Road Obstacles."
 - F. Testing of the vehicle ends with either a cracked egg or completion of 16 trials (8 forward and 8 backward).
 - G. Vehicles will be returned to the display area at the end of the competition.

VI. EVALUATION

Each vehicle will receive points based on how many impacts the car is able to withstand, the accuracy of the drawing, and on the design portfolio. The following rubric will be used. In the event of a tie, ranking will be determined by the most innovative design. The Event Coordinator will make this determination.

SCHEMATICS - CRASH TEST SLED

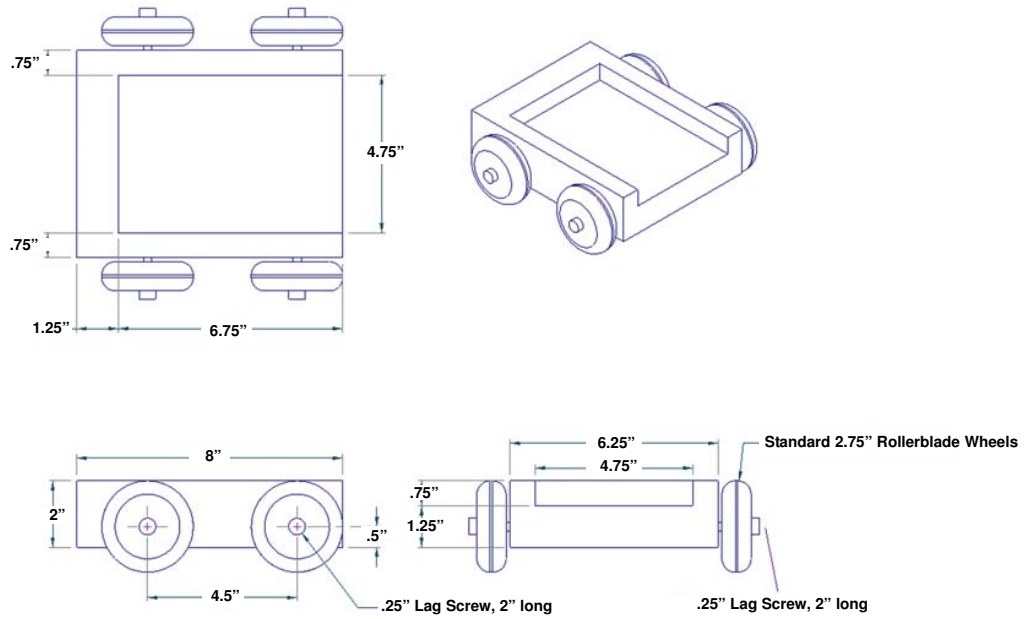

SCHEMATICS - CRASH TEST RAMP

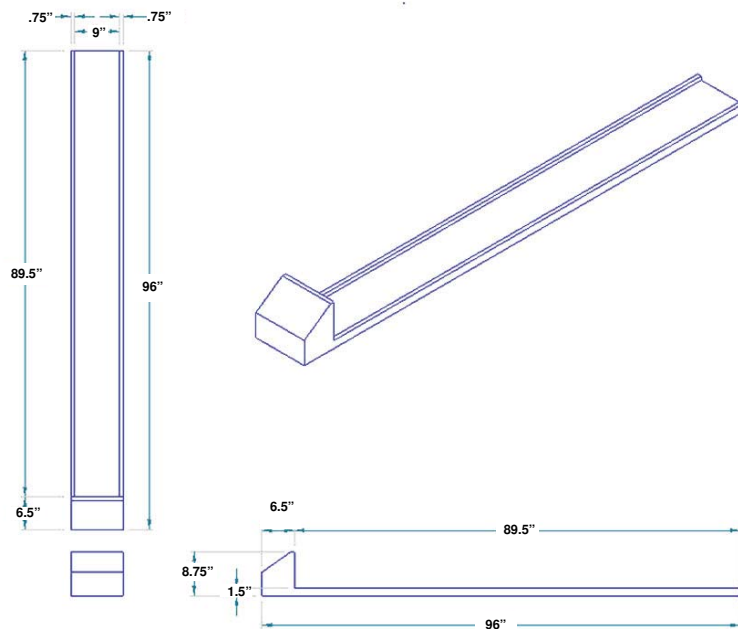



Participant/Team ID# _____

CRASH TEST			
2016 OFFICIAL RATING FORM	MIDDLE SCHOOL		

Survivability: Award points based on how high the car got BEFORE the egg cracked (e.g., if the egg cracked after a crash on step 5, award the points for step 4.)

Forward-facing height	4-feet = 5 points	6-feet = 10 points	Vertical Drop = 15 points
Backward-facing height	4-feet = 5 points	6-feet = 10 points	Vertical Drop = 15 points
Forward-facing height with obstacles	4-feet = 5 points	6-feet = 10 points	Vertical Drop = 15 points

Specifications			
----------------	--	--	--

	Minimal Performance 1-4 points	Adequate Performance 5-8 points	Exemplary Performance 9-10 points
Drawing	Drawing is not neat, does not reflect design of the car, or is missing. Not to scale. Measurements aren't included.	Drawing is neatly prepared and accurately reflects the design of the car, but is not to scale. Measurements are included.	Drawing is neatly prepared and accurately reflects the design of the car. The drawing is to scale. Measurements are included.
Portfolio	Portfolio is missing three or more items or is not present.	Portfolio is missing one of the following: documentation proving the elementary student was the primary lead in the design and construction; photos, essay describing the project and each person's part in it, or a time log documenting time spent with the elementary student.	Portfolio is complete with documentation proving the elementary student was the primary lead in the design and construction of the vehicle. Photos of the project are included as well as an essay describing the project and each person's part in it. A time log documenting the time spent with the elementary student on the project is included.
Design Specs - Construction	The car does not meet three or more design specs for length, width or height, or does not fit the test sled.	The car doesn't meet one of the design specs for length, width or height, or may not fit test sled.	The car meets design specs for height, width and length. It fits on the test sled properly.
Design Specs - Construction Part II	The passenger area does not provide comfortable seating. There is an obstruction of the windows and the controls are not accessible by the driver.	The car has seating for at least two passengers. There may be an obstruction of the windows or controls may not be accessible by the driver.	The car has seating for at least 2 passengers. Car has unobstructed view through the windows. Steering wheel is accessible by the driver.
Design Specs - Appearance	The car is missing three or more of the following: a clear windshield, front and back bumpers or a steering wheel. There is no safety system.	The car is missing one of: a clear windshield, front and back bumpers or a steering wheel. There is only one safety system.	The car has a clear windshield, front and back bumpers, a steering wheel and more than one safety system.
Design Specs - Appearance	Car has needs for improvement in three areas: glue usage, tight fitting pieces, or clean cuts. Car is not decorated.	Car is neatly done, but there is one need for improvement: glue usage, tight fitting pieces, or clean cuts. Car is painted or decorated. Follows theme.	The car is neatly done, using a proper amount of glue, tight fitting pieces, and cuts are clean. Car is painted well. The car follows published theme.

Record scores in the column spaces below.

Rules violations (a deduction of 20% of the total possible points) must be initialed by the evaluator, coordinator and manager of the event. Record the deduction in the space to the right.
Indicate the rule violated: _____

--

(To arrive at the TOTAL score, add any subtotals and subtract rules violation points, as necessary.)	TOTAL SCORE
--	--------------------

--

Comments:

I certify these results to be true and accurate to the best of my knowledge.

Evaluator: _____ Signature: _____

Printed name: _____



Creativity Challenge - HS

OPEN TO HIGH SCHOOL STUDENTS

I. GOAL

To stimulate elementary students' interest in TSA by encouraging high school TSA members to share their love and interest in technology.

II. PURPOSE

In this ON-SITE event, one elementary student (grades 1-5 or 6 - NOTE: SEE ELIGIBILITY SECTION BELOW) will work with a high school student in an on-site design problem. NOTE: This is a non-competitive event and does not earn points for your school toward the Chapter of the Year award. All High School and Elementary buddies will be recognized at the award ceremony.

III. ELIGIBILITY FOR ENTRY

This event is open to High School TSA Chapters. Entrants are limited to 10 teams of two students per chapter. Each team **MUST** have 1 elementary student, and one high school student. Students in 6th grade can be considered elementary students **ONLY IF** 6th grade is part of the elementary school in which they are currently enrolled. Students in sixth grade who are part of a K-8 or K-12 school are considered middle school students. Contact the state advisor if there are any questions regarding eligibility.

III. PROCEDURE/SPECIFIC REGULATIONS

- A. Participants report to the event area at the time/place listed in the conference program.
- B. The teams allowed 1 hour and 30 minutes to design and construct a solution.
- C. Each solution is tested as soon as the construction phase is completed.
- D. All work must be completed in the event area during the time specified for the event.
- E. All materials are provided. Only the materials issued to each team by the event coordinator may be used in the development of the solution.

IV. EVALUATION

Each team's solution is evaluated objectively. A finite measure, such as elapsed time, horizontal or vertical distance, and/or strength, is used to determine the best solution. Solution designs will be used to break ties. Only as a last resort does the event coordinator use subjective measurement, such as originality, to evaluate solutions.



Creativity Challenge - MS

OPEN TO MIDDLE SCHOOL STUDENTS

I. GOAL

To stimulate elementary students' interest in TSA by encouraging middle school TSA members to share their love and interest in technology.

II. PURPOSE

In this ON-SITE event, one elementary student (grades 1-5 or 6 - NOTE: SEE ELIGIBILITY SECTION BELOW) will work with a middle school student in an on-site design problem. NOTE: This is a non-competitive event and does not earn points for your school toward the Chapter of the Year award. All Middle School and Elementary buddies will be recognized at the award ceremony.

III. ELIGIBILITY FOR ENTRY

This event is open to Middle School TSA Chapters. Entrants are limited to 10 teams of two students per chapter. Each team **MUST** have 1 elementary student, and one middle school student. Students in 6th grade can be considered elementary students **ONLY IF** 6th grade is part of the elementary school in which they are currently enrolled. Students in sixth grade who are part of a K-8 or K-12 school would be considered middle school students. Contact the state advisor if there are any questions regarding eligibility.

III. PROCEDURE/SPECIFIC REGULATIONS

- A. Participants report to the event area at the time/place stated in the conference program.
- B. The teams allowed 1 hour and 30 minutes to design and construct a solution.
- C. Each solution is tested as soon as the construction phase is completed.
- D. All work must be completed in the event area during the time specified for the event.
- E. All materials are provided. Only the materials issued to each team by the event coordinator may be used in the development of the solution.

IV. EVALUATION

Each team's solution is evaluated objectively. A finite measure, such as elapsed time, horizontal or vertical distance, and/or strength, is used to determine the best solution. Solution designs will be used to break ties. Only as a last resort does the event coordinator use subjective measurement, such as originality, to evaluate solutions.



Fashion Design - MS

OPEN TO MIDDLE SCHOOL STUDENTS

I. PURPOSE

Students have the opportunity to research, develop, and create garment designs, garments, and portfolios that reflect the current year's published theme. Twelve (12) qualifying semifinalist teams participate in an on-site event in which they present their garment designs to the judges.

The theme for 2017 is: "Here Comes the Bride." Participants choose a culture, region, or time period that they have or will study in middle school. Participants research the traditions and cultural values demonstrated in that culture's wedding ceremony. Representations of traditional and non-traditional weddings are welcome, as long as they are historically and regionally accurate. Clothing from straight, gay, trans, and other relationships are welcome.

Participants then design and "create" 3 items (example: veil, man's vest, dress) that would be worn for the wedding. Participants can create clothing for men or women, and even three pieces for a single person, rather than for multiple people.

As part of the presentation, participant teams must explain the significance of the fashion items in the culture and the ceremony. Note: These items do not need to be sewn from scratch (although that is allowable) They may be "built" from found items (say, from a thrift store) and modified to fit the design needs. The final project is NOT required to include a bridal gown.

II. ELIGIBILITY FOR ENTRY

Entries are limited to two (2) teams of two to four (2-4) members per chapter.

III. TIME LIMITS

- A. Entries must be started and completed during the current school year.
- B. Semifinalists will be allowed ten minutes (10) for a presentation. A deduction of five (5) points will be incurred for exceeding the presentation time limit.

IV. PROCEDURE

- A. Participants check in their entry at the time and place stated in the conference program.
- B. Entries are reviewed by evaluators. Neither students nor advisors are present at this time. A semifinalist list in random order is posted.
- C. The semifinalists report to the event area at the time and place stated in the conference program.
- D. Each semifinalist team must have access to student TSA member models and the team-created fashion items to compete in the semifinals.



-
- E. Semifinalists sign up for times for presentation. These sessions are OPEN and will take place in front of an audience.
 - F. Semifinalists use the assigned time to present their designs. Models must be present and wearing the fashion items designed by the team. Models must be members of the team's TSA chapter.
 - G. Any type of item/garment design that is typical of responsible clothing design and creation is considered appropriate.
 - H. During the semifinals, participants will be allowed ten (10) minutes to complete the presentation (two [2] minutes for setup, six [6] minutes for the actual presentation, and two [2] minutes for removal). Points will be deducted from a team's score for exceeding the ten (10)-minute time frame allowed for the presentation.
 - I. Final evaluation from judges takes place immediately following the completion of the presentation.

V. REGULATIONS

- A. All work must be completed during the current school year. Participants will use a plastic storage box to submit their portfolio, fashion items, and any accessories that are not placed on hangers or mannequins. (Hangers and mannequins are NOT provided by COTSA).
- B. Documentation materials (comprising "a portfolio") are required and should be placed and secured in a clear front report cover. (The portfolio must be submitted with the garments.) The report must include the following single-sided, 8½" x 11" pages, in this order:
 - Title page with the event title, the conference city and state, and the year; one (1) page
 - Table of contents; one (1) page
 - Summary of research; two (2) pages
 - Interpretation of theme; two (2) pages
 - Explanation of the item, the materials used in its creation, textiles used, construction techniques used, etc.; two (2) pages
 - Design process sketches (hand-drawn); five (5) pages
 - References /resources; two (2) pages
- C. Items
 - The fashion items must be of presentation quality.
 - All designs and items should be appropriate for viewing at the state TSA conference.
 - Any portfolio or fashion item that depicts inappropriate or unacceptable designs will be disqualified.
 - Only the required number of items should be submitted for evaluation. Additional items, garments, and accessories may be used only in the semifinalist presentation and are not submitted for preliminary judging.
- D. The semifinalist portion of the event evaluates the quality of the team's presentation, as well as the team's knowledge and expertise pertaining to the entry in the following areas: overall garment design and originality, theme interpretation, construction techniques, and fabrics used.



VI. EVALUATION

Evaluation is based on points earned for the portfolio and garments, and a presentation. Scores on the portfolio, patterns and garments will determine the twelve (12) semifinalists. Points earned for the presentation will be added to the portfolio score to determine the final ranking of the top ten (10) finalists.



Participant/Team ID# _____

FASHION DESIGN - MIDDLE SCHOOL

2017-2018 OFFICIAL RATING FORM **MIDDLE SCHOOL**

Specifications

Go/No-Go: Before judging the entry, please ensure that these items are present and place a check mark in the box if they are. If an item is missing, leave the box blank and place a check mark in the box labeled "ENTRY NOT EVALUATED." If a check mark is placed in the "ENTRY NOT EVALUATED" box, the entry is not to be judged.

- Portfolio is complete; no required items are missing.
- Portfolio follows the format guidelines
- Portfolio is presented in specified report cover
- All required garments are included
- Entry Not Evaluated

Portfolio

Evaluators: Using minimal (1-4 points), adequate (5-8 points) or exemplary (9-10 points) performance levels as a guideline, record the scores earned for the event criteria in the column spaces to the far right.

	Minimal Performance 1-4 points	Adequate Performance 5-8 points	Exemplary Performance 9-10 points
Portfolio Components	Some parts of the portfolio are missing; the portfolio is unorganized, messy, and lacks quality.	Most components of the portfolio are present, adequately organized, and average in quality.	All components of the portfolio are included; strong effort and quality of work are evident.
Summary of Research	The summary is too brief and lacks the appropriate details expected for the event.	The summary of the research is sufficient; most of the key details are included.	The summary is organized, clear, and concise, with appropriate and necessary details included.
Interpretation of Theme	The interpretation of the theme is very weak and unconvincing.	The interpretation of the theme is clear, with some appropriate justification.	The interpretation of the theme is clear, concise, and thorough, with convincing justification.
Explanation of garments	The explanation is unclear, poorly organized, and does not accurately describe the garment types.	The explanation is loosely organized, with adequate attempts to describe the garment types and their production.	The explanation is clear, and concise and demonstrates extensive knowledge of garment types and production.
Design Process Sketches	Sketches are poorly executed and lack necessary details in the design process.	Sketches are complete as drawn and include most notations and references to the design process.	Sketches are well executed, organized, and clearly represent the design process.
Resources/References	Research is inadequate, with very few credible resources and references provided and/or documented.	Research appears adequate, with most important resources and references adequately documented.	Research is comprehensive, and all resources and references are properly documented.
SUBTOTAL (60 points)			

Quality of Garments

Evaluators: Using minimal (1-4 points), adequate (5-8 points) or exemplary (9-10 points) performance levels as a guideline, record the scores earned for the event criteria in the column spaces to the far right.

	Minimal Performance 1-4 points	Adequate Performance 5-8 points	Exemplary Performance 9-10 points
Effective construction techniques used/evident	Garment construction fails to meet accepted standards and techniques of construction in relation to the fabric selected.	Garment construction meets acceptable standards and construction techniques.	Garments show that a variety of appropriate techniques were used in the construction.
SUBTOTAL (10 points)			

Rules violations (a deduction of 20% of the total possible points) must be initialed by the evaluator, coordinator and manager of the event. Record the deduction in the space to the right.
Indicate the rule violated: _____

Record scores in the column spaces below.



Semifinalist On-Site Presentation

Evaluators: Using minimal (1-4 points), adequate (5-8 points) or exemplary (9-10 points) performance levels as a guideline, record the scores earned for the event criteria in the column spaces to the far right.

	Minimal Performance 1-4 points	Adequate Performance 5-8 points	Exemplary Performance 9-10 points	
Organization	Participants seem unorganized and unprepared for the presentation.	Participants are generally prepared for the presentation.	The presentation with the evaluators is logical, well organized, and easy to follow.	
Knowledge (x2)	Participants seem to have little understanding of the concepts in their project; answers to questions may be vague.	Participants exhibit an understanding of the concepts in their project.	Participants show clear evidence of a thorough understanding of the project.	
Articulation	The presentation is full of illogical thoughts that lack clarity.	The presentation is somewhat logical and easy-to-understand and follow.	The presentation provides a clear, concise, and easy-to-follow description of the project.	
Delivery	Participants are verbose, illogical in presenting, and use many "uhs, ums, hmms, etc."	Participants are logical and fairly well spoken, with little use of "uhs, ums, hmms, etc."	Participants are well-spoken, distinct, and clear throughout the presentation.	
Quality of garments on models	The garments do not appear to fit and/or are inappropriate for the person modeling (color, style, textures, etc).	The garments fit neatly and generally are well made for the person modeling.	Garments clearly are made and designed for the model--fitting nicely, with appropriate style, colors, textures, etc.	
SUBTOTAL (60 points)				

Time violation (a deduction of five (5) points will be incurred for being shorter than 3 three minutes or exceeding the five (5)-minute time limit for the length of the video). Record the deduction in the space to the right.

Rules violations (a deduction of 20% of the total possible points) must be initialed by the evaluator, coordinator and manager of the event. Record the deduction in the space to the right.
Indicate the rule violated: _____

(To arrive at the TOTAL score, add any subtotals and subtract rules violation points, as necessary.) **TOTAL SCORE (130 points)**

Comments:

I certify these results to be true and accurate to the best of my knowledge.

Evaluator: _____ Signature: _____

Printed name: _____



Fore!

OPEN TO HIGH SCHOOL STUDENTS

I. GOAL

To stimulate elementary students' interest in TSA by encouraging high school TSA members to share their love and interest in technology.

II. PURPOSE

The local parks and recreation department has recently begun work on renovating the municipal golf course. Prior to the renovation, there was an 9-hole themed miniature golf course which had become dated and unattractive. As part of the renovation, the Department of Parks and Recreation has the opportunity to update the course; they want to design and build an attractive course that is appealing to all of the city's residents and have put out a call for design ideas for a new 9-hole golf course.

Your design team, consisting of one elementary student (grades 1-5 or 6 - NOTE: SEE ELIGIBILITY SECTION BELOW) and one high school student, has been hired to design and develop one hole for the proposed miniature golf course.

III. ELIGIBILITY FOR ENTRY

This event is open to High School TSA Chapters. Entrants are limited to 10 teams of two students per chapter. Each team **MUST** have 1 elementary student (grades 1-5 or 6), and one high school student.

Students in 6th grade can be considered elementary students **ONLY IF** 6th grade is part of the elementary school in which they are currently enrolled. Students in sixth grade who are part of a K-8 or K-12 school would be considered middle school students. Contact the state advisor if there are any questions regarding eligibility.



III. SPECIFIC REGULATIONS

Your team will present, drawings of your design creation, a list of necessary materials, a constructed, playable table top model of your creation which was designed and constructed before the conference. The elementary student should be the primary lead in the design and construction of the model.

- A. Golf course holes must be turned into the event coordinator at the beginning of the conference to be displayed. Students may not pick up their models until the end of the conference.
- B. Portfolio: The high school student must present a portfolio documenting the project. Included in this portfolio should be:
 - A list of materials (including cost)
 - Photos of the project
 - An short essay describing the golf course hole and each person's part in the project. Included in this essay should be an explanation of how the par of the hole was determined.
 - A time log documenting the time spent with the elementary student on the project.
 - A colored blueprint/schematic of the hole with all parts clearly labeled.
- C. Model
 - The golf course hole model must be a playable tabletop model not to exceed 24" x 24".
 - The model must include a "tee" area.
 - The model must include a cup 1" in diameter.
 - The model must include a marble to serve as a miniature golf ball.
 - The team must design and develop a "putter" or launch mechanism to hit the ball on the hole.
 - In order to minimize costs, the model should be constructed primarily from recyclable materials.

IV. PROCEDURE

- A. Participants will turn in their golf course holes and design portfolios to the display area at the designated time.
- B. Each golf course hole will be demonstrated by the design team. The team's "putter" or launch mechanism will be used to propel the golf ball through the course.
- C. Golf courses will be returned to the display area at the end of the competition.

V. EVALUATION

Each golf course hole will be evaluated using the following rubric. The project will receive points based on the design portfolio prepared by the high school student. In the event of a tie, ranking will be determined by the most economically-produced model. The Event Coordinator will make this determination.



Participant/Team ID# _____

FORE!				Record scores in the column spaces below.
2016 OFFICIAL RATING FORM		HIGH SCHOOL		
Specifications				
	Minimal Performance 1-4 points	Adequate Performance 5-8 points	Exemplary Performance 9-10 points	
Portfolio	<p>The portfolio may be missing two or more of the following items and/or the information presented is not complete:</p> <ul style="list-style-type: none"> • A list of materials used in the creation of the hole. • Photographs detailing the work of the TSA member AND the elementary student in the creation of the model. • An essay describing in detail the hole and each person's part in the project. • A time log documenting the time spent with the elementary student. • A blueprint/schematic of the hole will all part/features clearly labeled. 	<p>Portfolio is complete and includes:</p> <ul style="list-style-type: none"> • A list of materials used in the creation of the hole. • Photographs detailing the work of the TSA member AND the elementary student in the creation of the model. • An essay describing in detail the golf course hole and each person's part in the project. • A time log documenting the time spent with the elementary student. • A blueprint/schematic of the hole will all part/features clearly labeled. 	<p>Portfolio is complete and easy to read and is clearly understandable. It includes:</p> <ul style="list-style-type: none"> • A detailed list of materials used in the creation of the hole. • Multiple photographs detailing the work of the TSA member AND the elementary student in the creation of the model. • A short essay describing in detail the golf course hole and each person's part in the project. • A detailed time log documenting the time spent with the elementary student. • A colored blueprint/schematic of the hole will all part/features clearly labeled. 	
Model	<p>The model is missing three or more items from the following:</p> <ul style="list-style-type: none"> • Fits within the 24" x 24" dimensions • Includes a "tee" area • Includes a cup 1" in diameter • Includes a marble to serve as a ball. • Has a student-developed putter/launch mechanism to hit the ball on the hole. • Is built from recycled materials. 	<p>The model includes/meets all but ONE of the following:</p> <ul style="list-style-type: none"> • Fits within the 24" x 24" dimensions • Includes a "tee" area • Includes a cup 1" in diameter • Includes a marble to serve as a ball. • Has a student-developed putter/launch mechanism to hit the ball on the hole. • Is built from recycled materials. 	<p>The model hole:</p> <ul style="list-style-type: none"> • Fits within the 24" x 24" dimensions • Includes a "tee" area • Includes a cup 1" in diameter • Includes a marble to serve as a ball. • Has a student-developed putter/launch mechanism to hit the ball on the hole. • Is constructed from recycled materials. 	
	<p>The hole makes poor use of the space; design indicates simple two-dimensional design. No special features such as tunnels or uneven topography are included.</p>	<p>The hole adequately uses the space provided; may include one feature such as a tunnel or uneven topography.</p>	<p>The hole takes full advantage of all available space. May include multiple levels or other features (e.g., tunnels or uneven topography).</p>	
	<p>The model is incomplete. Many parts of the model are missing. The hole is not well constructed.</p>	<p>The model is complete but there may be some difference between plans and actual model. Model includes greens, walkways, bumpers, tees, holes, flags and obstacles. Goal is apparent. The hole is well constructed.</p>	<p>The model accurately follows the drawings. The model is complete with greens, walkways, bumpers, tees, holes, flags and obstacles. The goal is readily apparent. The hole is well constructed and neatly presented.</p>	

Rules violations (a deduction of 20% of the total possible points) must be initiated by the evaluator, coordinator and manager of the event. Record the deduction in the space to the right. Indicate the rule violated: _____

(To arrive at the TOTAL score, add any subtotals and subtract rules violation points, as necessary.) **TOTAL SCORE**

Comments:

I certify these results to be true and accurate to the best of my knowledge.

Evaluator: _____ Signature: _____

Printed name: _____



Giant Jenga Tournament

OPEN TO MIDDLE AND HIGH SCHOOL STUDENTS

I. GOAL

To stimulate teamwork and communication skills through a creative problem-solving challenge.

II. PURPOSE

Part of developing a student who will be prepared for the challenges ahead in the 21st century is the development of teamwork and communication skills. Through this competitive event, played in tournament style, teams work to test those leadership skills as they work as a team to build a teetering block tower made of 2x4 blocks as high as possible without having it fall over.

Each of the blocks have been donated by the various TSA chapters in Colorado and may bear some sort of decoration on its edges and ends. The purpose behind having chapters contribute personalized blocks signifies that while each of our TSA chapters may look slightly different, together, we are very similar and all fit together to build a strong organization. Each COTSA chapter is encouraged to submit blocks to the COTSA State Office for this event.

III. ELIGIBILITY FOR ENTRY

This event is open to Middle and High School TSA Chapters. Entrants are limited to four (4) teams of two (2) to four (4) students per chapter.

IV. SPECIFIC REGULATIONS

- A. A Jenga set consists of 54 wooden blocks. Each block is made from a standard 2x4 and is 10.5” long.
- B. The initial Jenga tower has 18 levels of three blocks each. The blocks are placed adjacent to each other along their long side and perpendicular to the previous level (so, for example, if the blocks in the first level lie lengthwise north-south, the second level blocks will lie east-west).
- C. A “move” consists of taking one -- and only one -- block from any level (except the one below the incomplete top level) of the tower, and placing it on the topmost level in order to complete it.
- D. Blocks may be bumped to find a loose block that will not disturb the rest of the tower. Any block that is moved out of place must be returned to its original location before removing another block. The turn ends when the next person to move touches the tower or after ten seconds, whichever occurs first.
- E. The match ends when the tower falls in even a minor way—in other words, any piece falls from the tower, other than the piece being knocked out to move to the top.
- F. The winning team will be the team to successfully remove and place a block without causing the tower to fall or a brick to fall from the tower.



V. PROCEDURE

- A. The tournament will be bracketed prior to the conference and initial matches will be determined at random.
- B. A coin toss will be made to determine the team that will move first in a match.
- C. Blocks may be bumped to find a loose block that will not disturb the rest of the tower. Any block that is moved out of place must be returned to its original location before removing another block.
- D. The turn ends when the next person to move touches the tower or after ten seconds, whichever occurs first.
- E. The match ends when the tower falls in even a minor way—in other words, any piece falls from the tower, other than the piece being knocked out to move to the top.

VI. EVALUATION

The match ends when the tower falls in even a minor way—in other words, any piece falls from the tower, other than the piece being knocked out to move to the top. The winning team will be the last team to successfully remove and place a block on top of the tower without causing the tower to fall or a brick fall from the tower.



Integrated Autonomous Vehicle

OPEN TO MIDDLE AND HIGH SCHOOL STUDENTS

I. PURPOSE

The purpose of the challenge is for students to design, build, and operate an integrated autonomous vehicle. This vehicle must be able to navigate a defined course in both tele-operated (human-controlled) as well as autonomous (computer-controlled) modes. Through this challenge students will develop an understanding of the relationships between sensors and embedded controllers. Students will be required to utilize computational thinking principles to plan, control, and manipulate the motion of a vehicle.

This challenge encourages students to integrate the use of sensors and programming to develop a closed-loop feedback control system. Students will develop fluency in the vocabulary and concepts around microcontrollers and embedded computing. Students are required to document, present, and demonstrate the use of the engineering design cycle.

II. ELIGIBILITY FOR ENTRY

Eligibility is limited to two (2) teams of three (3) members per chapter. This event is open to high school and middle school students.

III. VEHICLE / ROBOT

- A. **SIZE:** The vehicle shall not exceed a rectangular footprint of 10" wide x 10" long.
- B. **WEIGHT:** The gross weight of the vehicle with battery shall not exceed 20 lbs in weight.
- C. **SAFETY:** Any vehicle deemed unsafe by the judges will be removed from competition, only to return at the judge's discretion.
- D. **CONTROL SYSTEM \ MICROCONTROLLER:** Vehicles may use any commercially available robotics control systems including, but not limited to: Lego RCX/NXT/EV3, VEX, Parallax, Arduino, Raspberry Pi, Beaglebone Black, or PCduino.
- E. **REMOTE \ TELE-OP CONTROL:** The vehicle shall integrate a method to manually operate and control that utilizes a non-physical interface. This system includes any publicly available radio modules in the ISM Band (WiFi, Bluetooth, XBee) or by Infrared (IR) remote.
- F. **BILL OF MATERIALS / BUDGET:** Each team shall submit a complete bill of materials / budget for the cost of their vehicle/robot. Present retail value of all parts, hardware, material, and electronics should be included using the attached spreadsheet. This includes all robot controllers, kits, sensors, batteries, and wires. Common items or salvaged recycled goods such as cardboard, popsicle sticks, soda cans, scrap wood should be included on the Bill of Materials (BOM) but should be listed at a cost of \$0.00. Teams will be rewarded for being resourceful and cost effective.



- G. **SENSORS:** Integration of sensors is highly encouraged. There are many commercial-off-the-shelf (COTS) sensors available that are compatible with any of the control systems / microcontrollers mentioned above. All electrical wiring, including sensors, must be clearly documented in the design notebook.

IV. PLAYING FIELD

- A. **FIELD DIMENSIONS:** The field will be built on a 4' x 8' sheet of $\frac{3}{4}$ " plywood sheet. The surface of the field is painted matte white. Lanes on the field are nominally 11.375" wide. Due to build tolerances, these may vary by as much as +/- 1 inch.
- B. **FIELD VARIANTS:** There will be three unique field variants for students to compete on. Each field has a score multiplier that reflects the relative difficulty of the challenge.
- C. **PRACTICE FIELD:** Classroom or practice fields may be constructed of plywood and 1x4" pine to match the challenge course. See drawing FIELD_DWG.pdf for specific course layouts and diagrams. This year the challenge has changed from previous years, please read the descriptions carefully if you've competed before. The teams can choose which field to run on. The fields will give the opportunity to complete runs and score highest possible score.
- D. **BEACONS:** A team may provide navigation beacons as a means to mark the course. Beacons may be infrared, visible spectrum or sonic. Sonic beacons in the audible range are subject to the judges' approval and any beacon deemed disruptive will be removed from the challenge (e.g., a continuous tone at 9 kHz). Once the beacon is placed it may not be moved until after the team placing it has completed its run.
- E. **MARKERS AND FIDUCIALS:** Teams may add flat, marking features on the course to aid in navigation. Fiducial markers shall be no larger than 4" wide x 4" long x 0.125" tall. The number of fiducial markers shall not exceed the number of intersections in the course.
- F. **TRACKING LINE:** Each course will feature a $\frac{3}{4}$ " black strip of electrical tape centered along the maze to provide contestants with the opportunity of integrating a line following algorithm. The tracking line terminates in 90 degree turns at each intersection of the maze.
- G. **FIELD PERIMETER:** Barrier walls 3- $\frac{1}{2}$ " tall will line the edge of the plywood. The barrier walls are constructed from standard 2" x 4" lumber.
- H. **FINISH ZONE:** An area approximately 11.375" x 12" marked in RED shall designate the finishing area for each challenge. Completion of the race shall be determined when any point of the vehicle crosses into the FINISH ZONE.
- I. **PAYLOAD PEDESTAL:** A payload shall be placed on a pedestal on the field. The pedestal will be a 1- $\frac{1}{2}$ " SCH 40 PVC Coupler (Home Depot SKU: SKU # 29399). The bottom of the payload will rest at a height of 2.25" from the bottom of the playing field. The payload pedestal will sit just outside the starting area for the vehicle.
- J. **PAYLOAD DEPOSIT AREA:** A 6" x 6" square box made from 1" x 2" Furring strips shall mark the location of the payload deposit. The Payload Deposit area will be centered along the TRACKING LINE in the FINISH ZONE.

V. THE CHALLENGE

- A. TRIALS: Each vehicle will have the opportunity to make three (3) timed runs on a course. The maximum time allowed to complete the course is 3 minutes.
- B. SCORING / TIMING: Each trial shall be scored based on the time and the difficulty of the course according to the following formula:

$$TimeScore = \frac{180 \text{ seconds} - CourseTime(s)}{180 \text{ seconds}} \times [CourseMultiplier] \times [50 \text{ points}] + PayloadBonus$$

Course Time shall be taken at the point when any part of the vehicle crosses over into the RED FINISH ZONE. Teams may still continue to deliver the PAYLOAD into the PAYLOAD DEPOSIT AREA so long as the total time does not exceed 3 minutes.

- C. FALSE STARTS: A false start shall be defined as any movement across the starting line by a vehicle before being signaled or otherwise permitted by the judge. A FALSE START results in a 20 point score deduction.
- D. FIELD PROGRESS BONUS: For each corner passed teams will receive a +10 point bonus to their score. The entire body of the robot must fully pass through the intersection for a FIELD PROGRESS BONUS to be awarded.
- E. INTEGRATED AUTONOMOUS: One of the three (3) trials for each team shall be manually student-operated by the remote control. All other rounds shall be fully autonomous. Autonomous mode must be initiated by a single button push on their vehicle.
- F. FIELD OPTIONS:
 - FIELD A: rectangle (right turns only). Multiplier = 1.00
 - FIELD B: turns (left turns only). Multiplier = 1.25
 - FIELD C: multiple turns (right and left) and a T-intersection (one route shorter than the other). Multiplier = 1.50

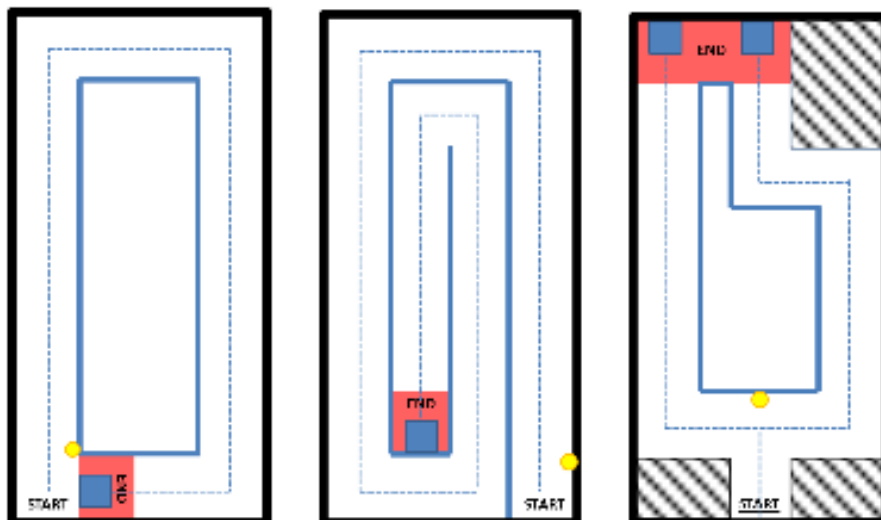



G. **PAYLOAD BONUS:** Teams will have the choice of taking a payload through the course. The payload is a standard tennis ball measuring nominally 2.63” in diameter and 2 oz. in weight. Points for manipulating and moving the payload will be awarded as follows:

- Moving or manipulating the payload: +5 points
- Successfully picking up the payload: +5 points
- Moving the payload to the end: +10 points
- Depositing the payload successfully: +15 points
- Any PAYLOAD tasks completed autonomously: 2x autonomous multiplier bonus.

H. **CELL PHONES & OTHER TECHNOLOGY:** The use of cell phones during competition is strictly prohibited unless being used to control the vehicle. Use of cell phones by spectators is also prohibited. If a judge sees a cell phone in the contest area they will ask that it be put away; if a judge sees the cell phone a second time, the person will be asked to leave the contest area.

VI. TECHNICAL DOCUMENTATION / PRESENTATION

A. **Technical Documentation.** The entire design process should be made available electronically through a website or blog. You may use Instructables, Google Sites, wix.com, blogger, wordpress, or your favorite web authoring tool. Through this webpage, you should document the entire engineering design process, illustrating your progress from design inception, iteration and testing, re-design, and final delivery / evaluation (competition day). A link to the technical documentation must be provided via the COTSA State Conference Early Submission Entry Form at: <http://goo.gl/hwsZvG> by February 1, 2017. Contestants will need to enter their contestant ID# and a contact email address. Any links submitted after the February 1 deadline will not be considered for competition. The technical documentation should include:

- **Bill of Materials (BOM) / Budget:** A complete list of all parts, materials, and components used on the vehicle. Additional bonuses will be awarded to teams that use readily available materials and low-cost solutions.
- **Technical drawings:** Complete mechanical engineering drawings of the vehicle shall be provided.
- **Drawings may be done by hand or using computer-aided design (CAD).**
- **The drawings should include at a minimum an orthographic or isometric sketch and three section views illustrating the front, top and side profiles of the vehicle with appropriate geometric dimensioning and tolerancing.**
- **Photos / Images / Video:** Include photos and images of the design process. We encourage you to leverage the use of digital media to capture your design process.
- **Electrical schematics:** Drawings of the wiring, power system and sensors shall be provided. Use color coding and labels on your schematic where appropriate.
- **Pseudo-code / algorithm:** Contestants should include a flow chart, diagram or illustration of their program and program flow.
- **Code:** Original source code your program. Your program should be fully documented and commented to allow judges to interpret your algorithm and program flow.
- **Data Tables and Calculations:** Tables of original experimental data illustrating the iterations, trials and calculations should be included and properly documented with dates and times of the experiments.



- B. Presentation. During the presentation time, each team will be expected to summarize their design and the design process to the judges. Teams should plan out and rehearse a 2- to 3-minute presentation on their vehicle. Note: A projector will NOT be available, but teams are encouraged to bring visual aids, models, or a poster. Suggested topics to include:
- Engineering design process.
 - Brainstorming and various ideas teams investigated.
 - Data, calculations and iterations taken.
 - Key highlights and features of their vehicle / robot.
 - Reflection and evaluation of their design success.
 - Discussion of obstacles encountered.
 - Possible changes / improvements for next year.
 - Overview of material captured in their design notebook.
- C. Q&A -Teams should be prepared for a question & answer session following their short presentation. Questions will focus primarily around the engineering design process, design choice, and rationale. Students should be prepared to defend the features and design choices of their vehicle.
- D. Code Review - Students may be asked to step through the logic of their program with judges. Judges will be looking for demonstration of understanding of the control system and algorithm implemented on the robot.

VII. EVALUATION

The following rubric will be used. In the event of a tie, a tie-breaking rounds may be held until a winner is determined.



Participant/Team ID# _____

INTEGRATED AUTONOMOUS VEHICLE					
2016 OFFICIAL RATING FORM			MIDDLE & HIGH SCHOOL		
Specifications					
Budget	\$0-\$100 50 points	\$100 - \$200 40 points	\$200 - \$300 30 points	\$300 - \$400 20 points	> \$400 10 points
Technical Drawing	A professional level of detail, all drawings are accurate. Elevation, plan, and cut/callouts are ready to ship to a fabricator. 40 points	Drawing is well detailed, dimensions are accurate and thorough, callouts / cut sheets are well detailed and accurate 30 points	Drawing is vague, dimensions are present, but not complete, or are vague or callouts / cut sheets are vague or lacking detail. 20 points	Drawing did not represent accurately the vehicle, no cut sheets or detail callouts. Dimensions not shown or not accurate. No electrical schematic 10 points	Comments:
Technical Interview	Team is able to demonstrate advanced understanding of all areas of the vehicle and the challenge, including alternate design strategies. 20 points	Team is able to converse freely about engineering, programming, physics, and mechanics of their vehicle. 15 points	Team is vague or unable to explain specific parts, and the principles behind their operation for their vehicle. 10 points	Team is unable to explain function, operation, programming, or construction of the vehicle. 5 points	Comments:
Programming/ Documentation	Programming shows a high level of expertise, creativity. May use unexpected data structures or a high level language, or both. 20 points	Programming is presented clearly with discussion of sensor arrays, loops, branches, or subroutines. 15 points	Programming documentation is presented, but lacks detail or is unable to be discussed by the programmer. 10 points	Little or no programming documentation. 5 points	Comments:
Course Time	The course scores (3) are added together and combined with the preceding scores. Highest total score wins. $\text{TimeScore} = ((180 \text{ s} - \text{CourseTime(s)}) / 180) * \text{CourseMultiplier} * 50 \text{ pts} + \text{PayloadBonus}$ Trial 1: $((180 \text{ s} - \text{_____}) / 180) * \text{_____} * 50 \text{ pts} + \text{_____} = \text{_____}$ Trial 2: $((180 \text{ s} - \text{_____}) / 180) * \text{_____} * 50 \text{ pts} + \text{_____} = \text{_____}$ Trial 3: $((180 \text{ s} - \text{_____}) / 180) * \text{_____} * 50 \text{ pts} + \text{_____} = \text{_____}$				Comments:
Rules violations (a deduction of 20% of the total possible points) must be initiated by the evaluator, coordinator and manager of the event. Record the deduction in the space to the right. Indicate the rule violated: _____					
(To arrive at the TOTAL score, add any subtotals and subtract rules violation points, as necessary.)					TOTAL SCORE
Comments:					
I certify these results to be true and accurate to the best of my knowledge. Evaluator: _____ Signature: _____ Printed name: _____					

Record scores in the column spaces below.



Mousetrap Tractor Pull

OPEN TO MIDDLE SCHOOL STUDENTS

I. PURPOSE

To allow students to demonstrate their ability to design and construct a vehicle powered only by a standard mousetrap spring, to pull as much weight as possible.

II. ELIGIBILITY FOR ENTRY

This event is open to Middle School TSA chapters. Entrants are limited to SIX (6) per school.

III. SPECIFIC REGULATIONS

- A. All entries must be designed and constructed before the conference.
- B. Vehicles must be turned into the event coordinator at the beginning of the conference to be displayed. Students may not pick up their vehicles until the end of the conference.
- C. Every entrant shall submit a complete set of sketches for the mousetrap vehicle detailing each part with basic dimensions. These sketches are to be completed on 8-1/2" x 11" paper.
- D. Although the mousetrap may be altered, a standard mousetrap spring may be the only power source for the vehicle. The mousetrap spring must accompany the vehicle the full length of the track. Only a standard mousetrap may be used. *No rat traps.*
- E. Vehicle Specifications:
 - The vehicle may be no longer than 16" at any time during the pull.
 - The vehicle may be no wider than 10" at any time during the pull.
 - The vehicle must have a fixed hook or eye in which a cup hook may be attached. It should be centered in the very back and 1/2" above the ground.
- F. The track will be 3 feet long. The vehicle must pull dead weight 2 feet. The surface that both the vehicle and the sled will travel on will be wood.
- G. The 'sled' will be a wooden device in which weight can be loaded. The weight sled may not be lifted at any time during the pull.
- H. No kits are allowed; the participant must create the vehicle from scratch.

IV. PROCEDURE

- A. Participants will turn in their vehicle to the display area at the beginning of the conference.
- B. Each vehicle will be given the opportunity to pull an appropriate starting weight. Those that successfully pull that given weight will then enter Round 2. The process will be repeated with weight being added to the sled in each round until only one vehicle remains.
- C. Participants must launch their own vehicles.



V. EVALUATION

The following rubric will be used to evaluate the vehicle. In the case of a tie, ranking will be determined by the most innovative design. The Event Coordinator will make this decision.



Participant/Team ID# _____

MOUSETRAP TRACTOR PULL

2016 OFFICIAL RATING FORM
MIDDLE SCHOOL

Pulling Trials: Record information about the trials.

Trial 1 - Weight _____	Trial 2 - Weight _____	Trial 3 - Weight _____	Trial 4 - Weight _____
Trial 5 - Weight _____	Trial 6 - Weight _____	Trial 7 - Weight _____	Trial 8 - Weight _____
Trial 9 - Weight _____	Trial 10 - Weight _____	Trial 11 - Weight _____	Trial 12 - Weight _____
Trial 13 - Weight _____	Trial 14 - Weight _____	Trial 15 - Weight _____	Trial 16 - Weight _____
Trial 17 - Weight _____	Trial 18 - Weight _____	Trial 19 - Weight _____	Trial 20 - Weight _____
Trial 21 - Weight _____	Trial 22 - Weight _____	Trial 23 - Weight _____	Trial 24 - Weight _____

Calculate points for pulling trials: Multiply the # of the highest successful trial by 2 (e.g., Trial 16 = 16 x 2 = 32 = Total Trial Points)

	Minimal Performance 1-4 points	Adequate Performance 5-8 points	Exemplary Performance 9-10 points
Drawing	Drawing is not neat, is not on 8.5" x 11" paper, is not accurate, or is missing. It is not to scale. Measurements are not included.	Drawing is neatly prepared on 8.5" x 11" paper and accurately reflects the design of the vehicle, but is not to scale. Measurements are included.	Drawing is neatly prepared on 8.5" x 11" paper and accurately reflects the design of the vehicle. It is to scale. Measurements are included.
Design Specs - Overall	The vehicle does not meet two or more design specs for length, width, or height or does not have a hook for pulling the sled.	The vehicle does not meet one of the design specs for length, width or height, or the fixed hook is not properly positioned.	The vehicle meets design specs for height, width, and length. It has a fixed hook properly positioned at the back of the vehicle.
Design Specs - Mousetrap	The vehicle is not powered only by a single, standard mousetrap.	N/A	The vehicle is powered only by a single, standard mousetrap.
	The vehicle has two or more needs for improvement: glue usage, tight fitting pieces, and cuts are clean. Vehicle is not decorated or themed.	The vehicle is neatly done, but there is one need for improvement: glue usage, tight fitting pieces, and cuts are clean. Vehicle is painted or decorated. Theme is not clear. Theme/decoration may occasionally interfere with operation of the vehicle.	The vehicle is neatly constructed, using a proper amount of glue, tight fitting pieces, and cuts are clean. Vehicle is decorated/themed. Theme/decoration does not interfere with operation of vehicle.

Rules violations (a deduction of 20% of the total possible points) must be initialed by the evaluator, coordinator and manager of the event. Record the deduction in the space to the right.
 Indicate the rule violated: _____

(To arrive at the TOTAL score, add any subtotals and subtract rules violation points, as necessary.) **TOTAL SCORE**

Comments:

I certify these results to be true and accurate to the best of my knowledge.

Evaluator: _____ Signature: _____

Printed name: _____

Record scores in the column spaces below.



On-Demand Video Challenge - MS

OPEN TO MIDDLE SCHOOL STUDENTS

I. PURPOSE

Participants use video skills, tools, and processes to communicate, entertain, inform, analyze and/or illustrate a topic, idea, subject, or concept. Participants demonstrate their abilities and skills in the field of impromptu digital videography.

II. ELIGIBILITY FOR ENTRY

This event is open to Middle School TSA Chapters. Entries are limited to one (1) team of 2-6 students per chapter.

III. SPECIFIC REGULATIONS

- A. Entries must be started and completed during the conference.
- B. The video must be 30-60 seconds in length.
- C. Participants will be given 24-hours to develop a storyboard and script based on a prompt given on site as well as collect video footage from the current state conference for use in the final video.
- D. Participants may NOT use stock footage, clips/footage prepared prior to the conference for the final project. All video footage must be the original work of the team and must have been completed during the event timeline.
- E. Participants may only use Royalty Free music or music of their own creation for their solution. Identification of this music must be included in the script and storyboard. In some cases, music may be provided by TSA as part of the problem. Should students create their own music for the production, it must be identified as such in the script and storyboard.
- F. Participants may solicit other chapter or conference participants to assist in collecting footage for their final solution, but only the registered participants are permitted to edit the final solution.
- G. Participants must submit the following on a flash drive (marked with the TEAM ID NUMBER) at the time and place indicated in the conference program:
 - The final video is saved as an AVI, MOV, MPG, MP4, or WMV file on a flash drive.
 - A copy of the script
 - A copy of the storyboard
 - The original on-demand video challenge release forms signed by individuals appearing in the production.
 - ** PLEASE NOTE: The video must be playable from the flash drive. If the movie does not open or play, the entry will be disqualified



-
- H. All entries/flash drives become the property of Colorado TSA and will not be returned after judging.
 - I. Teams may use no more than one (1) video camera for the video production.
 - J. Teams must edit their projects on a nonlinear editing system or their camera. Teams are responsible for providing their own editing and camera equipment.

IV. PROCEDURES

- A. Participants report to the event area at the time and place stated in the conference program.
- B. The event coordinator distributes the materials, information, directions, and deadlines to each team.
- C. Each team supplies its own video production and editing equipment that it wishes to use to complete its production. Entries will be submitted on a single USB flash drive for viewing on a personal computer.
- D. Entries are reviewed by evaluators. Neither students nor advisors are present at this time.
- E. Participants shoot their footage, which must be appropriate for the TSA community, only at officially sanctioned conference locations as described by the event coordinator. Teams are not allowed to shoot in sleeping rooms, restrooms, restaurants, or elevators/escalators. Participants may not disturb any event in progress, enter a restricted evaluation area, interrupt a conference function, or participate in behavior unbecoming to a conference participant. When the on-site prompt is picked up, the teams will be given any restrictions regarding filming on the specific property. Failure to follow these instructions will result in disqualification.

V. EVALUATION

Evaluation is based on the completed video production and the accompanying documentation. Depending on the stated purpose, videos are judged on story concept, artistic and/or social value, camera technique, transition and video pace, as well as technical attributes, creativity and organization, and the overall effect of the solution. The video should also incorporate the specified items (props, dialogue, music, etc.) as presented at the on-site problem.



**TSA ON DEMAND VIDEO CHALLENGE
CONSENT AND RELEASE**

I hereby give permission for images of my child or myself (as applicable), captured during Technology Student Association (TSA) activities through film, photo or digital camera, to be used solely for the purposes of TSA promotional materials and publications, and I waive any rights of compensation or ownership thereto.

Name of minor in images/video (please print)

Name of minor's parent/guardian (please print)

Name of adult in images/video (please print)

Parent/guardian or adult's signature (as applicable)

Date



Participant/Team ID# _____

ON-DEMAND VIDEO CHALLENGE			
2017-2018 OFFICIAL RATING FORM		MIDDLE SCHOOL	
Specifications			
<p>Go/No-Go: Before judging the entry, please ensure that these items are present and place a check mark in the box if they are. If an item is missing, leave the box blank and place a check mark in the box labeled "NOT EVALUATED." If a check mark is placed in the "ENTRY NOT EVALUATED" box, the entry is not to be judged.</p>			
<input type="checkbox"/>	Script and Storyboard are included on the flash drive.		
<input type="checkbox"/>	The video is included on the flash drive and opens to play.		
<input type="checkbox"/>	Entry Not Evaluated		
Production Documentation (30 points)			
<p>Evaluators: Using minimal (1-4 points), adequate (5-8 points) or exemplary (9-10 points) performance levels as a guideline, record the scores earned for the event criteria in the column spaces to the far right.</p>			
	Minimal Performance 1-4 points	Adequate Performance 5-8 points	Exemplary Performance 9-10 points
Script	The script is missing key attributes, such as character dialogue, nonverbal cues, etc.; the script is unorganized, and there is inconsistent spacing.	The script contains most key attributes and is correctly formatted; overall the script follows the video production.	The script is concise, fluid, and all of its attributes correlate clearly with the video production.
Storyboard	The storyboard is sloppy, seems to have been thrown together after the creation of the video, and/or it does not correlate with the final product.	The storyboard is drawn appropriately and largely correlates with the completed video.	The storyboard is of exceptional aesthetic and artistic value and clearly correlates with the video.
Professional and technical information	The summaries of academic/ITEEA standards used, summary of research/writing strategies, creation of storybooks similar to the annual design challenges, along with challenges encountered and team's solutions are poorly done and/or are incomplete. A list of tools, including software and techniques used in the creation of the storybook are poorly done and/or are incomplete. There are few references listed, and/or the references listed show little relevance to the project's goal.	The summaries of academic/ITEEA standards used, summary of research/writing strategies, creation of storybooks similar to the annual design challenges, along with challenges encountered and team's solutions are clear and complete. A list of tools, including software and techniques used in the creation of the storybook is included. There are a sufficient number of references listed; the quality is good.	The summaries of academic/ITEEA standards used, summary of research/writing strategies, creation of storybooks similar to the annual design challenges, along with challenges encountered and team's solutions are extremely well-written, detailed and are complete. A detailed list of tools, including software and techniques used in the creation of the storybook are included. Many quality references are listed reflecting research in writing and illustrating for children and child development as well as in the engineering/creation of books similar to the design challenge.
SUBTOTAL (30 points)			

Record scores in the column spaces below.

Production (70 points)			
Criteria	Minimal Performance 1-4 points	Adequate Performance 5-8 points	9-10 points
<p>Evaluators: Using minimal (1-4 points), adequate (5-8 points) or exemplary (9-10 points) performance levels as a guideline, record the scores earned for the event criteria in the column spaces to the far right.</p>			
Camera Handling	Serious problems with focus, steadiness, and framing are evident.	Most shots are clearly focused and framed, with adequate closeups included.	Steady and creative shots that enhance the video are utilized, and excellent close-ups are included.
Lighting	Numerous shots are improperly lit; bleaching, shadows, or unbalanced conditions may be evident in some shots; there is no evidence of an attempt to correct problems.	Most shots are properly lit, either through ambient lighting or the use of techniques to correct poor lighting conditions.	All shots are well lit, either through ambient lighting or the use of techniques to correct poor lighting conditions.
Audio	Audio may be unclear, distorted, or washed out from poor signal-to-noise ratio; there is evidence of the use of a built-in camera microphone that detracts from the message.	The audio is clear, with consideration given to a good signal-to-noise ratio; background or ambient noise may occasionally be a distraction.	The audio is clear and recorded with good signal-to-noise ratio, displaying skillful microphone choice, placement, and technique.
Continuity & Pacing	The story sequencing is confusing; shots are too long or "clipped," with edit points appearing "glitchy."	The pace and timing are well structured; clips move along and tell the story, with moderate use of transitions.	Shots logically pace the story along in an interesting way, with an excellent and purposeful use of transitions.
Video Effectiveness	The video does not meet project goals, presents an unclear message, and is sloppy overall.	The video topic is presented with insights; the video adequately meets the objective.	The video is clearly focused, with a rich variety of supporting material.
Aesthetics & Artisanship	The work is unorganized and sloppy; the display seems to be an afterthought, as if it were thrown together.	The work provides an organized presentation of essential issues in a logical format.	The work provides an exemplary use of layout and design principles to logically communicate important data.
Used of required elements	Required elements incorporated in the video appear as an afterthought.	Required elements used in the video add some artistic value and tend to further the story being told.	Required elements are integral to the production's story and artistic value.
SUBTOTAL (70 points)			

Time violation (a deduction of five (5) points will be incurred for being shorter than 30 seconds or exceeding the sixty (60)-second time limit for the length of the video). Record the deduction in the space to the right.

Rules violations (a deduction of 20% of the total possible points) must be initiated by the evaluator, coordinator and manager of the event. Record the deduction in the space to the right. Indicate the rule violated: _____

(To arrive at the TOTAL score, add any subtotals and subtract rules violation points, as necessary.) **TOTAL SCORE (100 points)**

Comments: _____

I certify these results to be true and accurate to the best of my knowledge.
 Evaluator: _____ Signature: _____
 Printed name: _____



Pin Design

OPEN TO MIDDLE AND HIGH SCHOOL STUDENTS

OVERVIEW:

A long-standing tradition at the national TSA conference has been the trading of state-specific lapel pins. In this competition, participants will design a color lapel pin that can be used by Colorado TSA to exchange at the next national conference. Winning pin designs will be developed into trading pins for the upcoming national TSA conference.

NOTE: Due to the complexity and the large number of entries in this event as well as the limited duration of the state conference, this event has an early submission deadline! Contestants should submit their entries as a single, multi-page PDF document via our upload form located at <http://googl/hwsZvG> by February 1, 2017. Participants will need to enter their STATE CONFERENCE ID# when submitting an entry. Entries not submitted electronically or are not received by the deadline will NOT be considered for competition.

I. PURPOSE

Provide a means for TSA members to demonstrate their ability to communicate design and layout skills.

II. ELIGIBILITY FOR ENTRY

Entries are limited to 1 per student. Open to HIGH SCHOOL and MIDDLE SCHOOL students.

III. SPECIFIC REGULATIONS

- A. The pin design is an individual event. No recognition will be given for a group effort.
- B. Only one entry per student is eligible for competition. If a student submits more than one entry, the first submission will be the one considered for competition.
- C. The entry must be started and completed during the current school year.
- D. The design must be a color computer-generated design. Hand-drawn designs will be disqualified.
- E. When submitting a design, contestants should prepare a single, multi-page PDF document (8.5" x 11") that contains:
 - **Design:** A single page showing the design in both actual size (not to exceed 1-1/4" x 1-1/4") and an enlarged version (not to exceed 6" x 6") to show detail. The design may be presented either in portrait or landscape layout. (Please note that the actual pin size may not exceed 1-1/4" in any direction. Contestants are reminded that the size and number of letters in the design should be taken into consideration; a letter on a 10" piece of paper will be reduced to 1/10" on a 1" pin. Therefore, fewer letters and greater size is recommended for a more decipherable pin.) This page should also include the contestant's individual ID number. Nothing else should appear on this page. This page will be printed by the state office and displayed at the state conference.



- **Description:** A one (1) page description of the design process (including research efforts, design plans, creation process and self evaluation). This would include an explanation of the designer's inspiration. This description should also include software programs used, artwork/graphic/photo sources used in the production of the graphic.
- **References:** All entries must be the original work of the participant. Computer generated type fonts and public domain computer clip-art may be used. All ideas, text or images from sources other than the designer must be cited (copyrighted or not). Cited works should be in MLA format (see the Documentation Style Guide in this book for formatting examples!).
- **Letters of Permission:** If copyrighted material is used, separate written permission must be included as well. Failure to follow this procedure will result in disqualification. If the artwork is completely original, this must be stated in the description.

- F. The PDF document is then to be submitted ELECTRONICALLY via our submission upload page at: <http://goo.gl/hwsZvG>. Participants will need to enter their contestant ID# and a contact email address.
- G. All submissions are to be received by 11:59 p.m. FEBRUARY 1, 2017.
- H. The pin must include the official TSA logo letters, the Colorado TSA logo or the official TSA logo. The TSA emblem can be used only in accordance with trademark policies that appear on the national TSA website (www.tsaweb.org). From the homepage, click on About TSA and then Trademark Policies. The TSA logo may be used with or without the registered trademark symbol (the circle R).
- K. The pin design must also represent the state in some way - either through theme, shape, colors or subject (e.g., mountains).
- L. All entries in this event become the property of Colorado TSA and may or may not be used in future promotional materials and publications. Colorado TSA reserves the right to modify the winning designs for production purposes.

V. PROCEDURE

- A. Registration: Event participants must register and follow the guidelines for the event in accordance with the procedures established for the conference.
- B. ALL designs must be submitted electronically in PDF format to be considered for competition.

V. EVALUATION

- A. Middle School level and High School level winning designs will be recognized at the awards ceremony. However, winning pin designs may or may not be selected to be the pins that represent Colorado as the trading pins at national competition. A Middle School and a High School pin will be produced for trading at the national conference.
- B. Copies of previous winning pin designs shall not be used.
- C. The following rubric will be used in the evaluation of entries.



Participant/Team ID# _____

PIN DESIGN			
2016 OFFICIAL RATING FORM		MIDDLE & HIGH SCHOOL	
Specifications			
	Minimal Performance 1-4 points	Adequate Performance 5-8 points	Exemplary Performance 9-10 points
Evaluators: Using minimal (1-4 points), adequate (5-8 points) or exemplary (9-10 points) performance levels as a guideline, record the scores earned for the event criteria in the column spaces to the far right.			
Inspiration for Graphic Design	Little or no discussion of the inspiration for the graphic is included; no, or illogical, order of the design process is evident.	General overview of the design process is included, as is a basic description of the inspiration for the graphic.	An organized and logical overview of the entire design process, which details inspiration for the graphic design, is included.
Design Process	Explanation does not discuss the technical development of the graphic; software packages used are not mentioned; frequent grammar and spellings errors are evident; MLA format is not used, and/or the citations are inadequate.	General overview of the technical development of the graphic (which mentions by name the primary software packages used in the design) is included; a few grammar and spelling errors are evident; MLA format is used for an adequate number of resources.	Detailed and concise description of the technical development of the design (with discussion of all software packages used in the design) is included; proper grammar and spelling are evident; MLA format is used for the citations.
Relevance	Brief and weak explanation of how the graphic design correlates to the challenge is included, and/or the explanation is illogical.	The challenge is discussed in the explanation, but questions arise in trying to understand the correlation between the challenge and the design.	Explanation of relevance (i.e., how the final graphic design relates to the challenge) is clear and complete.
First Impression of Graphic	Design is messy and/or damaged; it includes three (3) or more of the following: dull/rough edges, hard to read fonts, smudges, smears on the graphic, extraneous markings.	Design has several good points, but some details detract from the overall quality; it includes two (2) or fewer of the following: dull/rough edges, hard to read fonts, smudges, smears on the graphic, extraneous markings.	Graphic is striking, elegant and includes one (1) or none of the following: dull/rough edges, hard to read fonts, smudges, smears on the graphic, extraneous markings.
Usefulness	Graphic has no correlation to the state TSA affiliate it is intended to relate to; design does not work for the intended purpose.	Design generally works for its intended purpose, but it may be a little too big or too small in size; design correlates to the intended state TSA affiliate.	The design is a perfect size for the intended purpose; there is strong evidence for correlation of the design to the TSA affiliate.
Dominance	Eyes are drawn away from what should have been focal point by some other component of the graphic.	An attempt is made to use a graphic component that will draw attention to the design's main idea, but the result is confusing.	The design's main components draw eyes to the appropriate location and/or focal point of graphic.
Balance and Proportion	Design seems unbalanced; too little and/or too many graphic elements are included, and they are out of proportion.	Design is somewhat balanced but some graphic elements are too large and/or too small; the design is not proportioned.	All design elements included are balanced and equally proportioned.
Use of Graphic Design Principles	Design principles (alignment, consistency, contrast, unity, white space) are not incorporated into the graphic, and/or they are considered as an afterthought.	Graphic is missing two (2) or fewer design principles (alignment, consistency, contrast, unity, white space), but the overall layout is aesthetically pleasing.	Graphic is aesthetically pleasing and all design principles are incorporated into the design and layout.
Graphic Elements	Design uses more than the number of colors specified, gradients and/or photographs. Design colors are not separated. Design does not utilize metal color of the pin in the design.	Design incorporates no more than the maximum number of colors specified. Colors may not be separated by a distinct border. The design may include gradients and/or photographs.	Design incorporates no more than the maximum number of colors specified. Colors are separated by a distinct border. The design does not use gradients. The design does not incorporate any photographs. Design incorporates the metal color of the pin in the design.

Record scores in the column spaces below.

Proof of permission to use copyrighted image(s) must be included. Clip art must be documented. Failure to provide this information will result in DISQUALIFICATION. No permission is needed for the use of the TSA logo by affiliated chapters.

Rules violations (a deduction of 20% of the total possible points) must be initiated by the evaluator, coordinator and manager of the event. Record the deduction in the space to the right.
Indicate the rule violated: _____

(To arrive at the TOTAL score, add any subtotals and subtract rules violation points, as necessary.) **TOTAL SCORE**

Comments:

I certify these results to be true and accurate to the best of my knowledge.

Evaluator: _____ Signature: _____

Printed name: _____



Rat Trap Drag Race

OPEN TO HIGH SCHOOL STUDENTS

I. PURPOSE

To allow students to demonstrate their ability to design and construct a vehicle powered only by a standard rat trap spring, to travel a specified distance as fast as possible.

II. ELIGIBILITY FOR ENTRY

This event is open to High School TSA Chapters. Entrants are limited to SIX (6) per school.

III. SPECIFIC REGULATIONS

- A. All entries must be designed and constructed before the conference.
- B. Vehicles must be turned into the event coordinator at the beginning of the conference to be displayed. Students may not pick up their vehicles until the end of the conference.
- C. Although the rat trap can be altered, a standard rat trap spring may be the only power source for the vehicle.
- D. The rat trap spring must accompany the vehicle the full length of the track.
- E. Vehicle Specifications:
 - The vehicle may be no longer than 16" at any time during the race.
 - The vehicle may be no wider than 10" at any time during the race.
- F. The track will be 15' long.
- G. The surface the vehicles will travel on will be hotel-grade carpet.
- H. If the vehicle does not meet the specifications, it will have points deducted from the final score.
- I. Only a standard rat trap may be used.
- J. No kits are allowed; the participant must create the vehicle.

IV. PROCEDURES

- A. Participants will turn in their vehicle to the display area at the beginning of the conference.
- B. Participants must launch their own vehicles
- C. Each vehicle will be launch once and timed. The top 16 vehicles will go to the next round.
- D. The subsequent rounds are single-elimination, head-to-head races with the winner advancing through the bracket.
- E. Vehicles will be returned to the display area at the end of the competition.



V. EVALUATION

The rubric on the following page will be used in the evaluation of this event. In the case of a tie, ranking will be determined by the most innovative design. The Event Coordinator will make this decision. In the case of a tie, ranking will be determined by the most innovative design. The Event Coordinator will make this decision.

Rubber Band Powered Cars

OPEN TO MIDDLE AND HIGH SCHOOL STUDENTS

I. PURPOSE

To allow students to demonstrate their ability to design and construct a vehicle powered only by a rubber band and a bladed-propeller.

II. ELIGIBILITY FOR ENTRY

This event is open to Middle School and High School Chapters. Entrants are limited to THREE (3) per school.

III. SPECIFIC REGULATIONS

- A. All entries must be designed and constructed before the conference.
- B. Cars must be turned into the event coordinator at the beginning of the conference to be displayed. Students may not pick up their cars until the end of the conference.
- C. Student must make car from scratch in the year it is raced. (No kits)
- D. Racers may use any commercial wheels, axles and bladed propellers (as shown in the illustration at the right.)
- E. Vehicle Specifications:
 - The vehicle should resemble a commercially produced automobile (a sedan, pickup truck, or sports car for example) and not just be of simple stick & propeller configuration.
 - The vehicle body must be completely enclosed - not just have a profile of a vehicle shape.
 - The car may not exceed 24 inches in length.
 - The car may not exceed 8 inches in width.
 - The car may not exceed 10 inches in height.
 - The car will be powered by a single 7" x 1/8" rubber band (also known as a file band) attached to the bladed propeller (as illustrated above).
 - The car must be designed so that an eyelet is placed at the front of the car, 1/4" from the floor.
 - The car must be powered solely by the rubber band and bladed propeller; the rubber band should NOT be used in a manner other than to provide power to the propeller.





-
- F. The track will be 20' long x 15" wide. The surface of the track will be hardwood flooring (hotel dance floor).
 - G. The cars will race against the stopwatch. Each car will race three times, and an average speed will be calculated.
 - H. If the vehicle does not meet the specifications, it will have points deducted from the final score.

IV. PROCEDURES

- A. Participants will turn in their car to the display area at the beginning of the conference.
- B. Participants must launch their own cars.

V. EVALUATION

The vehicle will be evaluated using the following rubric. In the event of a tie, ranking will be determined by the most economically-produced model. The Event Coordinator will make this determination.



Silent Movie

OPEN TO MIDDLE AND HIGH SCHOOL STUDENTS

I. PURPOSE

Participants use video production skills to create a “silent” movie and then create a musical score to accompany the film. The use of silent films gets students to think about music and its application to other forms of art and technology. Scoring for silent movies improves students’ intellectual ability and their ability to think abstractly.

II. ELIGIBILITY FOR ENTRY

This event is open to Middle School AND High School Chapters. Entries are limited to one (1) team of 2-6 students per chapter.

III. SPECIFIC REGULATIONS

- A. Entries must be started and completed prior to the conference.
- B. The video must be at three (3) to five (5) minutes in length.
- C. Participants must create, script, storyboard and produce the video footage for a movie in the style of vintage silent movies. Participants must then produce an original musical score to accompany the movie. No other sound should accompany the movie. If any other sound/ sound effect (e.g., clatter of a movie projector to create ambiance) accompanies the movie other than the musical score, the entry will be disqualified.
- D. Participants may NOT use stock footage. All video footage must be the original work of the participants.
- E. Participants may NOT use Royalty Free music for their final solution. All the music must be the original composition/creation of the participants.
- F. The final musical score may be produced digitally through a range of available software available to the students (e.g., Garageband), or may be performed by a musician/musical group and recorded for later addition to the film. If the performance is to be recorded:
 1. The musical score should be the original work of the participants. No use of royalty free or copyrighted music may be used.
 2. Participants must document who performed the music and must include a release form from the performers in the documentation.
- G. Participants may solicit other chapter members to assist in collecting footage for their silent movie and or musical score, however, representatives from the team are limited to six (6).



-
- H. Due to the complexity of this event as well as the limited duration of the state conference, this event has an early submission deadline! Contestants should upload the entry to YouTube as an UNLISTED video (as an unlisted video, the video will not appear in any of YouTube's public spaces such as search results, a person's own channel, or the Browse page. Only people with whom participants share the link will be able to view it). Once the video is uploaded, go to the COTSA Early Submission form located at: <http://goo.gl/hwsZvG> and submit the URL (along with required documentation in PDF format). All entries must be received by 11:59 p.m. February 1, 2017. Contestants will need to enter their STATE CONFERENCE ID# when submitting an entry. Entries not submitted electronically or are not received by the deadline will NOT be considered for competition.
- I. Participants must also submit via the COTSA Early Submission form a documentation portfolio, containing the following:
- A copy of the script
 - A copy of the storyboard
 - A four-column cue sheet listing the scenes, the action, music suggestions that go with each action, and the location and length in the film into which the music should fit.
 - Students may use whatever musical production software is available to them to create the musical score.
 - A written copy of the score and documentation of the software used to create the musical piece.
 - The original release forms signed by individuals appearing in or performing for the production.

IV. PROCEDURE

- A. Entries are reviewed by evaluators. Neither students nor advisors are present at this time.

V. EVALUATION

Evaluation is based on points earned for the portfolio elements, the quality of the video production, and the overall effectiveness of the musical score. The film portion will be judged on story concept, artistic and/or social value, camera technique, transition, video pace, as well as technical attributes, creativity and organization.



TSA SILENT MOVIE

PHOTO / FILM/ VIDEO CONSENT AND RELEASE

I hereby give permission for images of my child or myself (as applicable), captured during Technology Student Association (TSA) activities through video/film, photo or digital camera, to be used solely for the purposes of TSA competitions, promotional materials and publications, and I waive any rights of compensation or ownership thereto.

Name of minor in images (please print)

Name of minor's parent/guardian (please print)

Name of adult in images (please print)

Parent/guardian or adult's signature (as applicable)

Date



TSA SILENT MOVIE

PERFORMANCE CONSENT AND RELEASE

I /We hereby give permission for the use of my/our performance of an original musical piece created by:

for the Technology Student Association (TSA) Silent Movie competitive event. I/We understand that the performance used in this competitive event may be used for purposes of this competitive event and also may be used for future promotion of this event as well as TSA in general. I/We hereby waive any and all rights of compensation or ownership thereto.

Name(s) of performer(s)

Signature of performer

Signature of performer

Signature of performer

Signature of performer

Date



Participant/Team ID# _____

SILENT MOVIE			
2017-2018 OFFICIAL RATING FORM		MIDDLE SCHOOL	
Specifications			
Go/No-Go: Before judging the entry, please ensure that these items are present and place a check mark in the box if they are. If an item is missing, leave the box blank and place a check mark in the box labeled "NOT EVALUATED." If a check mark is placed in the "ENTRY NOT EVALUATED" box, the entry is not to be judged.			
<input type="checkbox"/>	Script and Storyboard are included on the flash drive.		
<input type="checkbox"/>	Cue Sheet and Musical Score are included on the flash drive.		
<input type="checkbox"/>	The video is included on the flash drive and opens to play.		
<input type="checkbox"/>	Entry Not Evaluated		
Production Documentation (20 points)			
Evaluators: Using minimal (1-4 points), adequate (5-8 points) or exemplary (9-10 points) performance levels as a guideline, record the scores earned for the event criteria in the column spaces to the far right.			
	Minimal Performance 1-4 points	Adequate Performance 5-8 points	Exemplary Performance 9-10 points
Script	The script is missing key attributes, such as character dialogue, nonverbal cues, etc.; the script is unorganized, and there is inconsistent spacing.	The script contains most key attributes and is correctly formatted; overall the script follows the video production.	The script is concise, fluid, and all of its attributes correlate clearly with the video production.
Storyboard	The storyboard is sloppy, seems to have been thrown together after the creation of the video, and/or it does not correlate with the final product.	The storyboard is drawn appropriately and largely correlates with the completed video.	The storyboard is of exceptional aesthetic and artistic value and clearly correlates with the video.
SUBTOTAL (20 points)			

Record scores in the column spaces below.

Production (50 points)			
Criteria	Minimal Performance 1-4 points	Adequate Performance 5-8 points	Exemplary Performance 9-10 points
Evaluators: Using minimal (1-4 points), adequate (5-8 points) or exemplary (9-10 points) performance levels as a guideline, record the scores earned for the event criteria in the column spaces to the far right.			
Camera Handling	Serious problems with focus, steadiness, and framing are evident.	Most shots are clearly focused and framed, with adequate closeups included.	Steady and creative shots that enhance the video are utilized, and excellent close-ups are included.
Lighting	Numerous shots are improperly lit; bleaching, shadows, or unbalanced conditions may be evident in some shots; there is no evidence of an attempt to correct problems.	Most shots are properly lit, either through ambient lighting or the use of techniques to correct poor lighting conditions.	All shots are well lit, either through ambient lighting or the use of techniques to correct poor lighting conditions.
Continuity & Pacing	The story sequencing is confusing; shots are too long or "clipped," with edit points appearing "glitchy."	The pace and timing are well structured; clips move along and tell the story, with moderate use of transitions.	Shots logically pace the story along in an interesting way, with an excellent and purposeful use of transitions.
Video Effectiveness	The video does not meet project goals, presents an unclear message, and is sloppy overall.	The video topic is presented with insights; the video adequately meets the objective.	The video is clearly focused, with a rich variety of supporting material.
Aesthetics & Artanship	The work is unorganized and sloppy; the display seems to be an afterthought, as if it were thrown together.	The work provides an organized presentation of essential issues in a logical format.	The work provides an exemplary use of layout and design principles to logically communicate important data.
SUBTOTAL (50 points)			

Music (50 Points)			
Criteria	Minimal Performance 1-4 points	Adequate Performance 5-8 points	Exemplary Performance 9-10 points
Evaluators: Using minimal (1-4 points), adequate (5-8 points) or exemplary (9-10 points) performance levels as a guideline, record the scores earned for the event criteria in the column spaces to the far right. PLEASE NOTE: THIS SECTION HAS A 2X MULTIPLIER ON THE SUBTOTAL FOR THIS SECTION!			
Cue Sheet	The cue sheet is sloppy, seems to have been created after the creation of the finished piece and/or it is missing critical elements or does not correlate with the final product.	The cue sheet is included and lists the scenes, action, and music suggestions. May include location and how music links to how the music should fit.	The cue sheet is in proper format, listing the scenes, the action, music suggestions that go with each action, and the location and length in the film into which the music should fit.
Musical Score	Musical score is incomplete or missing; score does not follow musical conventions.	The musical score is included and represents the music for the movie but may contain errors in notation or musical convention.	The musical score is included and accurately represents the music for the movie. Score follows the convention of written music, including appropriate measure spacing, key and time signature notations, etc.
Creativity and Uniqueness	The musical idea is overly familiar or is a cliché; no variety or exploration of musical elements (range, timbre, dynamics, tempo, rhythm, and melody) is evident.	The work involves some original aspects or manipulations of musical ideas; it explores and varies at least one or more musical elements.	The piece includes highly original, unusual, or imaginative musical ideas; it explores and varies at least two or more musical elements.
Artanship	The piece gives no sense of a completed musical idea; there is no clear beginning, middle, or end section; the form appears random, rather than organized.	One musical element has been used to organize the musical ideas and overall form, which are somewhat coherent.	The piece presents at least one complete musical idea; the piece has a coherent and organized form with a clear beginning, middle, and end; musical elements are used to organize the musical ideas
Energy and Style	The piece lacks liveliness, vitality, and vigor; there is no flair, elegance, or grace to the piece. The music does not enhance the movie.	The piece generates an initial level of energy that appeals to the listener; the style is somewhat distinctive. The music does not enhance the movie.	The liveliness and forcefulness of the piece excite the listener; the style is truly unique and serves to enhance the story, message and theme of the movie.
SUBTOTAL (50 POINTS)			

Record scores in the column spaces below.

Record scores in the column spaces below.



Time violation (a deduction of five (5) points will be incurred for being shorter than 3 three minutes or exceeding the five (5)-minute time limit for the length of the video). Record the deduction in the space to the right.

Rules violations (a deduction of 20% of the total possible points) must be initiated by the evaluator, coordinator and manager of the event. Record the deduction in the space to the right. Indicate the rule violated: _____

(To arrive at the TOTAL score, add any subtotals and subtract rules violation points, as necessary.)

TOTAL SCORE (180 points)

Comments:

I certify these results to be true and accurate to the best of my knowledge.

Signature:

Evaluator:

Printed name:



T-Shirt Design

OPEN TO MIDDLE AND HIGH SCHOOL STUDENTS

OVERVIEW:

Participants in this event develop and submit electronically in PDF format a T-shirt design, which can be adopted as the Colorado state delegation T-shirt to be worn at the National TSA conference.

NOTE: Due to the complexity and the large number of entries in this event as well as the limited duration of the state conference, this event has an early submission deadline! Contestants should submit their entries as a single, multi-page PDF document via the COTSA State Conference Early Submission Entry Form located at <http://goo.gl/hwsZvG> by February 1, 2017. Contestants will need to enter their STATE CONFERENCE ID# when submitting their entry. Entries that are not submitted electronically or are not received by the deadline will NOT be considered for competition.

I. PURPOSE

Provide a means for TSA members to demonstrate their ability to communicate design and layout skills.

II. ELIGIBILITY FOR ENTRY

This event is open to Middle School and High School Chapters. Entries are limited to one (1) entry per student.

III. SPECIFIC REGULATIONS

- A. The T-shirt design is an individual event. No recognition will be given for a group effort.
- B. The student should develop a design for the back of the T-shirt as well as an accompanying design for the front left pocket area of the Shirt.
- C. The student should create a design for the back of the shirt (it must fit on a standard 8.5" x 11" piece of paper in portrait orientation).
- D. The student should also create a design for the left chest area of the front of the shirt not to exceed 5" x 5".
- C. The design of the shirt may have a maximum of three (3) colors. This does not include the color of the shirt (for example, if a white shirt is used, white can be incorporated into the design along with three other colors).
- D. The design should reflect the current year's national conference theme which can be found at <http://www.tsaweb.org/Themes-and-Problems>.



- E. The following information MUST be included in the design:
- The words “TSA National Conference”
 - Date of the National Conference
 - Location of the National Conference (City & State)
 - The theme for the National Conference
 - Either the Colorado TSA logo, or the official TSA logo
 - The type face(s) may be original in design or may consist of a traditional-type style(s). The required alphanumeric characters may be incorporated as an integral part of the illustration.
- F. Public domain computer clip art may be included in the design. Use of copyrighted or registered artwork in design is prohibited without verified permission from the original artist/publisher,
- G. Students DO NOT have to print out the design or prepare a mock up of the shirt. Contestants should submit their entries electronically as a single, multi-page PDF document via the COTSA State Conference Early Submission Entry Form located at <http://goo.gl/hwsZvG> by 11:59 p.m. on February 1, 2017. Contestants will need to enter their STATE CONFERENCE ID# when submitting their entry. Entries that are not submitted electronically or are not received by the deadline will NOT be considered for competition.
- H. When submitting the designs, students should submit a SINGLE, MULTI-PAGE PDF FILE, containing the following items:
- **Design:** A full-color design for the back of the shirt (no larger than 8.5” x 11” - portrait orientation). This page should also include the contestant’s individual ID number. Nothing else should appear on this page.
 - **Design Part II:** A full-color design for the front of the shirt (no larger than 5” x 5”). This page should also include the contestant’s individual ID number. Nothing else should appear on this page.
 - **Blackline Masters:** Clean blackline masters for EACH COLOR used in the design. These will be used to create the screen print separations.
 - **Documentation:** A one (1) page description of the design process (including research efforts, design plans, creation process and self evaluation). This would include an explanation of the designer’s inspiration. This description should also include software programs used, artwork/graphic/ photo sources used in the production of the graphics.
 - **References:** All entries must be the original work of the participant. Computer generated type fonts and public domain computer clip-art may be used. All ideas, text or images from sources other than the designer must be cited (copyrighted or not). Cited works should be in MLA format (see the Documentation Style Guide in this book for formatting examples!).
 - **Letters of Permission:** If copyrighted material is used, separate written permission must be included as well. Failure to follow this procedure will result in disqualification. If the artwork is completely original, this must be stated in the description.
- I. All submissions are to be received by 11:59 p.m. on FEBRUARY 1, 2017.
- J. Copies of previously submitted (winning or non-winning) designs shall not be used.



IV. PROCEDURE

- A. Registration: Event participants must register and follow the guidelines for the event in accordance with the procedures established for the conference.
- B. All winning entries will become the property of Colorado TSA. Colorado TSA reserves all rights to use and modify the designs for use on the state delegation t-shirt.

V. EVALUATION

The designs will be evaluated using the following rubric. In the event of a tie, ranking will be determined by the Event Coordinator.



Participant/Team ID# _____

T-SHIRT DESIGN			
2016 OFFICIAL RATING FORM		MIDDLE & HIGH SCHOOL	
Specifications			
	Minimal Performance 1-4 points	Adequate Performance 5-8 points	Exemplary Performance 9-10 points
Evaluators: Using minimal (1-4 points), adequate (5-8 points) or exemplary (9-10 points) performance levels as a guideline, record the scores earned for the event criteria in the column spaces to the far right.			
Design Specs: Artwork	T-shirt design is poorly prepared, is not in color, or has more colors than specified. Design is NOT presented in PDF format, or does not show both front/back designs of shirt.	T-shirt design in color. Design consists of no more than three colors (not including the color of the shirt). Design is not presented in PDF format or may show only the front or back design of the T-shirt.	T-shirt design is prepared neatly and in color. Design consists of no more than three colors (not including the color of the shirt). The design is presented in PDF format and shows both front and back designs of T-shirt.
	Artwork is not clear and all elements are not readable/recognizable. Design may be missing two or more of the following: • The words "TSA National Conference" • The Colorado TSA logo or official TSA logo • Dates of the National Conference • Location of the National Conference • The theme of the design reflects some aspect of Colorado and Colorado TSA • The words "Colorado TSA"	Artwork is clear and all elements are readable/recognizable. Design may be missing one of the following elements: • The words "TSA National Conference" • The Colorado TSA logo or official TSA logo • Dates of the National Conference • Location of the National Conference • The theme of the design reflects some aspect of Colorado and Colorado TSA • The words "Colorado TSA"	Artwork is clear and all elements are distinct and easily readable/recognizable. Design includes: • The words "TSA National Conference" • The Colorado TSA logo or official TSA logo • Dates of the National Conference • Location of the National Conference • The words "Colorado TSA"
	The artwork DOES NOT reflect, interpret or in some other way communicate the theme of the national conference. Design also does not include some element that reflect, interprets or in some other way communicates a sense of the specified theme as outlined in the rules.	N/A	The artwork reflects, interprets, or in some other way communicates the theme of the design reflects some aspect of Colorado and Colorado TSA.
First Impression of Graphic	Design is messy and/or damaged; it includes three (3) or more of the following: dull/rough edges, hard to read fonts, smudges, smears on the graphic, extraneous markings.	Design has several good points, but some details detract from the overall quality; it includes two (2) or fewer of the following: dull/rough edges, hard to read fonts, smudges, smears on the graphic, extraneous markings.	Graphic is striking, elegant and includes one (1) or none of the following: dull/rough edges, hard to read fonts, smudges, smears on the graphic, extraneous markings.
Usefulness	Graphic has no correlation to the state TSA affiliate it is intended to relate to; design does not work for the intended purpose.	Design generally works for its intended purpose, but it may be a little too big or too small in size; design correlates to the intended state TSA affiliate.	The design is a perfect size for the intended purpose; there is strong evidence for correlation of the design to the TSA affiliate.
Dominance	Eyes are drawn away from what should have been focal point by some other component of the graphic.	An attempt is made to use a graphic component that will draw attention to the design's main idea, but the result is confusing.	The design's main components draw eyes to the appropriate location and/or focal point of graphic.
Balance and Proportion	Design seems unbalanced; too little and/or too many graphic elements are included, and they are out of proportion.	Design is somewhat balanced but some graphic elements are too large and/or too small; the design is not proportioned.	All design elements included are balanced and equally proportioned.
Use of Graphic Design Principles	Design principles (alignment, consistency, contrast, unity, white space) are not incorporated into the graphic, and/or they are considered as an afterthought.	Graphic is missing two (2) or fewer design principles (alignment, consistency, contrast, unity, white space), but the overall layout is aesthetically pleasing.	Graphic is aesthetically pleasing and all design principles are incorporated into the design and layout.
Graphic Elements	Design uses more than the number of colors specified, gradients and/or photographs. Design colors are not separated.	Design incorporates no more than the maximum number of colors specified. The design may include gradients and/or photographs.	Design incorporates no more than the maximum number of colors specified. The design does not use gradients. The design does not incorporate any photographs.

Record scores in the column spaces below.

Proof of permission to use copyrighted image(s) must be included. Clip art must be documented. Failure to provide this information will result in DISQUALIFICATION. No permission is needed for the use of the TSA logo by affiliated chapters.

Rules violations (a deduction of 20% of the total possible points) must be initiated by the evaluator, coordinator and manager of the event. Record the deduction in the space to the right.
Indicate the rule violated: _____

(To arrive at the TOTAL score, add any subtotals and subtract rules violation points, as necessary.)

TOTAL SCORE

Comments:

I certify these results to be true and accurate to the best of my knowledge.

Evaluator: _____ Signature: _____

Printed name: _____



Theatrical Set Design

OPEN TO HIGH SCHOOL STUDENTS

I. PURPOSE

Participants demonstrate an understanding of and aptitude for architectural design along with the development of plans, as well as construction and modeling techniques and practices as applied to the theatre industry by developing a set of architectural plans and related materials for an annual theatrical set design challenge and construct a physical, as well as a computer-generated model, to accurately depict their design.

II. ELIGIBILITY FOR ENTRY

This event is open to High School TSA Chapters. Entries are limited to one (1) team of 2-6 students per chapter.

III. SPECIFIC REGULATIONS

The Design:

- A. The set design is based on the show as specified in the annual design challenge. For 2016-2017 the play is: "Arsenic and Old Lace"
- B. Participants must be prepared to make an oral presentation the design concept, how it supports the script, practicality of the set design and usability of the set design.
- C. The design must be the work of the students and should be completely original.
- D. Participants will prepare working drawings/floor plan of the set and should be drawn to scale of 1/4" = 1'.
- E. The set is to be designed for a stage with the following specifications (see illustration on next page). Any mobile set pieces should fit within the wing area when not in use. Mobile set pieces should be included in the design/model presented.
 - Proscenium opening: 38' wide and 20' high
 - Apron: 62' wide x 5' deep
 - Stage - from the curtain line to the back traveler/cyclorama/scrim: 32'
 - Wings - from edge of proscenium opening to wall: 12' (both sides)
 - Exit Doors - there are two (2) 36" wide standard doors leading to dressing/green rooms/ exits at the back of the stage, one on either side, 4' from the back wall.
 - Fly Space - There is no fly system above the stage; only working area for lighting systems.
 - Actor Movement: Space should be allotted for actor movement.
 - Mobile Set Pieces: Any mobile set pieces should be included in the model.

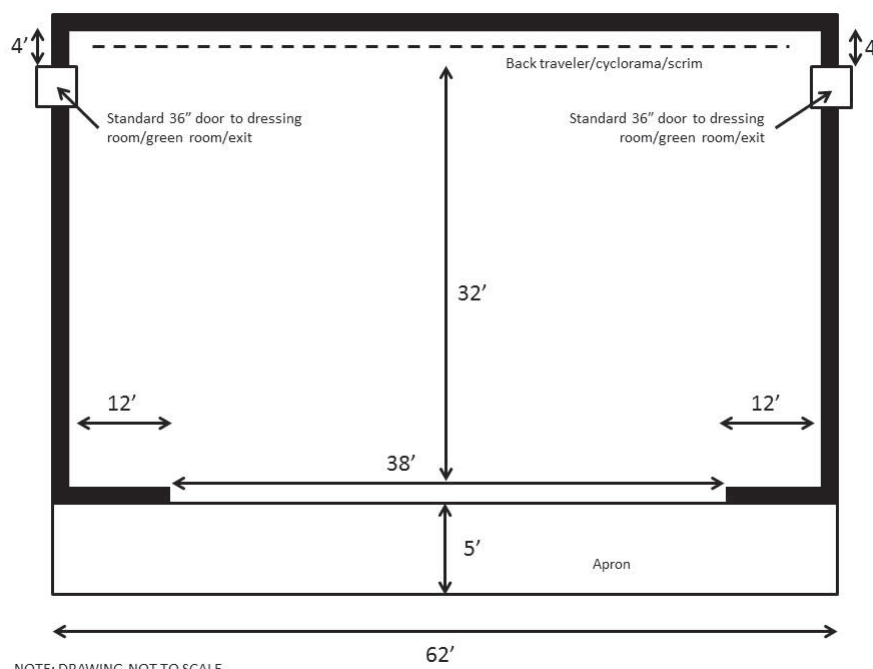

- Curtains - The stage is equipped with a grand drape just inside the proscenium opening, a teaser immediately behind with a tormentor. Three borders and legs are available for use (they can be adjusted for set design), and each wing has tabs to mask off-stage areas. (See illustration below).

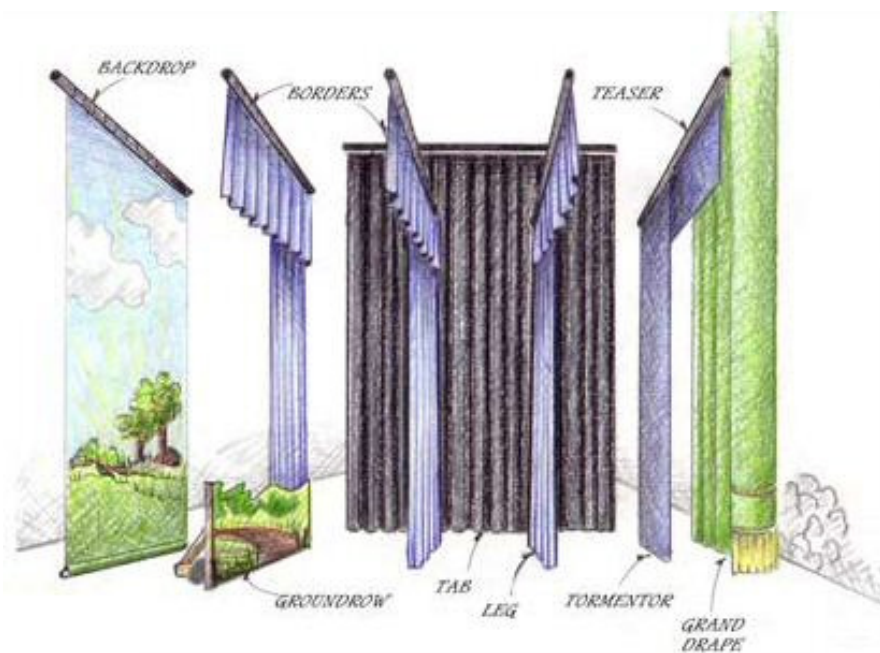

https://en.wikipedia.org/wiki/Theater_drapes_and_stage_curtains



-
- F. Mentorship: The design team is required to seek the mentorship of an architect, set designer or other related professional and must document the mentorship for inclusion in the portfolio (see Mentorship Verification form).

The Documentation:

- A. Documentation materials (comprising “a portfolio”) are required and should be secured in a clear front report cover. The report cover must include the following single-sided, 8½” x 11” pages, in this order:
 - 1. Title page with the event title, the conference city and state, and the year; one (1) page
 - 2. Table of contents; pages as needed
 - 3. A description of how the individual/team interpreted the design challenge and an explanation of the style and merits of the design concepts; one (1) page
 - 4. A schedule of finish materials for all surfaces of the final set design, including colors, fabrics, building materials (samples may be included as supplemental materials (NOTE: This is not a list of the materials used to construct the model!). Pages as needed.
- B. Initial design sketches of set design and printer/plotter-generated copies of CAD drawing of the set’s floor plan (each drawing to be submitted on maximum drawing sheet cut size B [11” x 17”] with appropriate scale size noted on the drawing); pages as needed
- C. An elevation view of the design from the audience perspective
- D. A suggested lighting plot for the set.
- E. A 3-D modeling/rendering drawing of the individual/team’s final design with appropriate details included; drawing sheet size B, 11” x 17”; one (1) page
- F. Plan of Work log that indicates preparation for the event, as noted by date, task, time involved, team member responsible, and comments (see Plan of Work log); pages as needed
- G. Mentorship Verification form; one (1) page
- H. List of resources/references; pages as needed
- I. Nothing that identifies a participant’s name, school, or chapter can be included on the model or in the documentation portfolio.



The Model:

- A. Model construction concepts, materials, techniques, and applications:
 - The model is to be on a 24" x 24" site board and built at 1/4" scale and centered in the middle of the site board; allow for a perimeter around the entire model.
 - Balsa wood, illustration board, or foam core or similar materials are suggested for (but not limited to) use as set walls, etc.
 - Foam core board that is 1/2" thick or greater is recommended for use as the site board for the model.
 - Dowels may be used to represent columns or circular components.
 - Participants should pay close attention to the scale of all materials as they relate to the scale of the model.
 - The model may not include any electrical or battery-powered enhancements.
 - No glass or liquid may be used as part of any model.

IV. PROCEDURES

- A. Participants work to complete their entry according to the event regulations.
- B. Participants check in their entries at the time and place stated in the conference program. No more than two (2) team members submit and place the model and documentation.
- C. Entries are reviewed by evaluators. Neither students nor advisors are present at this time. A semifinalist list in random order is posted.
- D. The individual semifinalist or two (2) representatives from each semifinalist team report to the event area at the time and place stated in the conference program. Semifinalists will sign up for a presentation/interview time and arrive at their specified time.
- E. Semifinalists will use their models and documentation for reference during the presentation/interview process.
- F. No more than two (2) team members pick up the team's entry from the display area at the time and place stated in the conference program.

V. EVALUATION

Evaluation is based on points earned for the portfolio, the design process, the architectural model, and the semifinalist interview. For more specific information, please refer to the official rating form.



TECHNOLOGY STUDENT ASSOCIATION PLAN OF WORK

Date	Task	Time Involved	Team Member Responsible	Comments
1				
2				
3				
4				
5				
6				

Advisor Signature: _____



THEATRICAL SET DESIGN - HIGH SCHOOL

MENTORSHIP VERIFICATION

I certify that I have served as a mentor to the student(s) named below. (This completed and signed form is a requirement of individual/team participation in the TSA competition, Theatrical Set Design). Chapter advisors must verify the mentorship experience by signing this form.

Mentor (please print)

Occupation (please print)

Employer (please print)

Signature of Mentor

Date

Student(s) involved (please print)

Signature of student(s)

Date

TSA Chapter Advisor (printed name and signature)

Date



Participant/Team ID# _____

THEATRICAL SET DESIGN

2017-2018 OFFICIAL RATING FORM **HIGH SCHOOL**

Specifications

Go/No-Go: Before judging the entry, please ensure that these items are present and place a check mark in the box if they are. If an item is missing, leave the box blank and place a check mark in the box labeled "NOT EVALUATED." If a check mark is placed in the "ENTRY NOT EVALUATED" box, the entry is not to be judged.

- Portfolio is included in a clear plastic cover.
- Portfolio contains all the required elements
- Model accompanies portfolio
- Entry Not Evaluated

Production Documentation (30 points)

Evaluators: Using minimal (1-4 points), adequate (5-8 points) or exemplary (9-10 points) performance levels as a guideline, record the scores earned for the event criteria in the column spaces to the far right.

	Minimal Performance 1-4 points	Adequate Performance 5-8 points	Exemplary Performance 9-10 points
Portfolio components	Portfolio is unorganized and/or is missing three or more components.	Portfolio is missing one or two components, and/or it is loosely organized, and/or it lacks sufficient content.	All components are included in the portfolio; content and organization are excellent.
Description of design interpretation	The description of the design and style is unclear or vague, and/or major grammatical/spelling errors are evident.	The description of the design and explanation of the style are included, but they are unclear and/or contain some grammatical/spelling errors.	The description and merits of the design and explanation of the style are clear, effective and convincing, and without grammatical/spelling errors.
Schedule of finish materials	Many elements of the interior and exterior finish schedules are missing or incomplete.	Most, but not all, elements of the interior and exterior finish schedules are included.	All interior and exterior finish schedules/materials are detailed and explained in an exemplary manner.
Drawings	A few of the required drawings are present, but they are lacking in quality.	Most, but not all, of the required drawings are included and are in the proper format.	All required drawings are included and are exemplary in format.
3D modeling or rendering	The drawing is missing or poorly executed and does not use appropriate/necessary details of the design challenge.	The drawing is included, but it is missing some key elements and necessary details of the design challenge.	The drawing completely and effectively represents all aspects of the design challenge, including necessary details.
Plan of work log	The Plan of Work log lacks major elements of the plan documentation.	The Plan of Work log is somewhat complete, and generally reflects the time and work necessary for the project.	The Plan of Work log completely and accurately reflects the time and work necessary for the project.
Mentor verification form	There is little or no effort to provide mentorship verification.	There is evidence that the mentor was available during the design process.	There is clear evidence of the appropriate use of the mentor in the design process.
Resources/References	There is little or no effort to provide resources and references.	Resources and references included are generally presented appropriately.	There is clear evidence of the appropriate use of applicable resources and references.
SUBTOTAL (80 points)			

Record scores in the column spaces below.

Design Challenge

Evaluators: Using minimal (1-4 points), adequate (5-8 points) or exemplary (9-10 points) performance levels as a guideline, record the scores earned for the event criteria in the column spaces to the far right.

Criteria	Minimal Performance 1-4 points	Adequate Performance 5-8 points	9-10 points
Effectiveness of Design	The design is ineffective in meeting the needs of the challenge.	The design is somewhat effective in meeting the needs of the challenge.	The design is exemplary and clearly effective in meeting the needs of the challenge.
Access and flow	The design reflects an ineffective traffic flow pattern and use of space to gain access to the original structure and addition.	The design reflects a somewhat effective traffic flow pattern and use of space to access the set.	The design presents a clear, effective traffic flow pattern and full consideration of the use of space.
Aesthetic appeal	There is little evidence of consideration of aesthetics and audience appeal in the design.	There is some evidence that aesthetics and audience appeal have been considered in the design.	There is clear evidence that aesthetics and audience appeal are fully and effectively integrated into the design.
Creativity and innovation	The design lacks originality and exhibits few, if any, creative and/or innovative applications.	Some unique, innovative, and creative concepts are incorporated in the overall design.	Unique, creative and innovative approaches have met the challenges of, and have been incorporated into, the design.
SUBTOTAL (40 points)			

Model

Evaluators: Using minimal (1-4 points), adequate (5-8 points) or exemplary (9-10 points) performance levels as a guideline, record the scores earned for the event criteria in the column spaces to the far right.

Criteria	Minimal Performance 1-4 points	Adequate Performance 5-8 points	9-10 points
Quality of construction	Construction is of poor quality and appearance, with little or no attention to neatness.	Construction is somewhat neat and has appropriate quality and appearance.	Construction is of excellent quality and exemplary appearance.
Use of materials	The choice of materials is ineffective and inadequate for the type and scale needed.	There is effective choice of materials and some attention to scale.	There is effective and excellent use of materials and accurate choice of scale.
Design representation	The model is ineffective in depicting the requirements of the design challenge.	The model is somewhat effective in depicting the requirements of the design challenge.	The model clearly and effectively incorporates and depicts all aspects of the design challenge.
SUBTOTAL (30 points)			

Rules violations (a deduction of 20% of the total possible points) must be initiated by the evaluator, coordinator and manager of the event. Record the deduction in the space to the right.
Indicate the rule violated: _____

(To arrive at the TOTAL score, add any subtotals and subtract rules violation points, as necessary.) **TOTAL SCORE (150 points)**

Comments:

I certify these results to be true and accurate to the best of my knowledge.

Evaluator:

Signature:

Printed name:



Underwater ROV

OPEN TO MIDDLE AND HIGH SCHOOL STUDENTS

I. PURPOSE

The challenge is a test of the accuracy, robustness and design of an Underwater Remotely Operated Vehicle (ROV). The vehicle will navigate a course laid out in the hotel swimming pool that will be disclosed at the State Conference. The course will consist of an obstacle course with items like tunnels, hoops, pylons, and payloads to deliver. Specific course requirements will be sent to chapter advisors via email. Please review the rubric carefully.

II. ELIGIBILITY FOR ENTRY

This event is open to Middle School and High School Chapters. Entries are limited to TWO (2) of 2-6 members per chapter.

III. SPECIFIC REGULATIONS

- A. All entries must be turned in at the designated time. Each team is responsible for signing up for a technical interview time. The whole team will attend the technical interview.
- B. Every entry shall include technical notebook, along the lines of the new TSA portfolio guidelines. The notebook shall contain:
 - A title page with the event title, state conference information, including date of conference.
 - A typewritten description of the vehicle, including the building system/components used and the design or engineering process used in designing and building the ROV. Photos or pictures may be included, and special features of the vehicle/programming and student driver interface (remote control) should be documented.
 - A set of technical drawings of the vehicle. The drawings will be standard orthographic, plan view, or other standard technical drawing format. Cutouts, exploded views, and multiple views are encouraged. Drawings may be done either by hand, or CAD generated.
 - At least one (1) page of schematic drawings representing the vehicle's electrical and control systems. Block diagrams are acceptable, but more points will be awarded for more detailed schematics.
 - A programming log if applicable, including a printout of the complete program for operation. Comments in the program log are encouraged.
 - A Safety Assurance Affidavit, signed by your advisor, stating that the ROV was Designed and built during this current school year, and that they believe it is safe to run in the pool.
- C. Vehicles may be constructed from a kit or may be built from scratch, more points will be awarded for student designed models vs. one built or modeled from a kit. Kits might include the SeaPerch kit (which can be seen at: <http://www.seaperch.org> . If building the ROV from scratch, note that a 12-volt power supply will be supplied at the event, other sources of power may be used, but you must supply your own if anything other than 12V DC is needed. 12V DC is the maximum voltage allowed.



-
- D. Each team will be expected to discuss project flow, performance and engineering aspects of their vehicle. Discussions may or may not be limited to the technical interview. Due to the highly technical nature of the challenge, expect the judges to ask the team questions.
 - E. Vehicles deemed unsafe by the judges will be removed from competition. If any part of the vehicle is removed, falls off, or leaks into the pool or tank, the vehicle will be automatically removed and disqualified. Any exposed wire connections will be seen as unsafe, and will result in the ROV being disqualified. Glass of any sort, including glass light bulbs that might shatter due to thermal shock will also be seen as unsafe and will result in disqualification.
 - F. Ultrasonic, infrared, touch, motion, light sensors, and distance encoders may be used. Cameras may be used, and a viewing device to see the image from the camera. No images may be used other than that from the ROV mounted camera.

IV. THE COURSE

Competitors should come prepared to get wet, and may wear shorts or swim suits if desired. Tasks may or may not have to be performed in a specific order. The exact course layout will be disclosed at the conference.

Three students are allowed "On Deck" at the time of the run, navigating the obstacle course. They are not allowed to touch the robot or manipulate it in any way other than using their designed controls. The students will be designated: One (1) Pilot and two (2) Deck Hands. The Pilot is the only one allowed to control the ROV. The two Deck Hands are allowed to coach, direct, and tell the Pilot what to do, but may not touch the remote controls or have any control of the ROV in any way. The Deck hands are allowed to help with cord management, hold monitors, laptops, etc. The pilot's view of the course may be obstructed for extra points; the Deck Hand's view will not be obstructed. The pilot may have another device to view an image from the ROV, but only images that come from the ROV are allowed to be viewed.

Tasks may include:

- Passing through one or more rings/hoops/gates, and then backing through the same route. Picking up a ring, hoop or small object and delivering it. There may be multiple objects to collect, with points earned for each object collected and delivered home.
- Entering and illuminating a cave. The ROV's lighting system must be switchable (it must be able to be turned on and off, at the appropriate times). The lighting system may be operated either manually or automatically (there may be a photo sensor to detect whether or not the light source on the ROV is turning on and off).



V. AUTONOMOUS OPERATION

Competitors may opt for an additional challenge of autonomous operation. Competitors must ask the judges specifically for this extra challenge. This challenge will consist of an autonomous attempt to retrieve a ring from testing pool. Three attempts will be given and each attempt will end at the return to the surface of the ROV. For example, the judges will signal the team to begin the attempt, the robot will descend and make its attempt to secure the ring. When the robot returns to the surface, with or without the ring, the attempt is over. Each attempt has a one minute time limit. Extra points will be awarded for Autonomous operation.

VI. EVALUATION

The vehicle will be evaluated using the following rubric. In the event of a tie, ranking will be determined by the most economically-produced model. The Event Coordinator will make this determination.



Participant/Team ID# _____

UNDERWATER ROV			Record scores in the column spaces below.
2016 OFFICIAL RATING FORM		MIDDLE & HIGH SCHOOL	
Specifications			
	Minimal Performance 1-4 points	Adequate Performance 5-8 points	Exemplary Performance 9-10 points
Evaluators: Using minimal (1-4 points), adequate (5-8 points) or exemplary (9-10 points) performance levels as a guideline, record the scores earned for the event criteria in the column spaces to the far right.			
Technical Interview	Team knew little of the intricacies of the technical nature of their product.	Team was well informed, able to discuss in detail the engineering and logical framework of their design.	Team exceeded the judges' expectations with regard to the level of detail of their design. This might include the ability to present calculations, interactive design stages and advanced construction or control system.
Portfolio and Drawings	Portfolio is not complete, not organized well, or lacks description of engineering process. Drawings lack sufficient detail and measurements. Schematics are incomplete, or do not represent the electrical system.	Portfolio has required components but may not clearly describe the design or build process. Drawings may be missing measurements or important vie. Schematics lack some important details.	Portfolio is complete and well organized. Design process is clearly communicated. Drawings and schematics are complete and have sufficient detail.
ROV Construction & Design	ROV is not constructed well, has exposed wire connections, components not waterproofed or other deficiencies. (NOTE: Brushless motors are considered waterproof without any additional coatings or casings)	ROV appears well built, and wire connections and motors are waterproofed but may have been directly produced or designed from a kit. (NOTE: Brushless motors are considered waterproof without any additional coatings or casings)	ROV is clearly well-designed and built, has extra features, all connections and motors are waterproofed. ROV is designed by students and is not from a kit. (NOTE: Brushless motors are considered waterproof without any additional coatings or casings)
NOTE: SCORES FOR THE TECHNICAL PERFORMANCE & OBSTACLE COURSE ARE WORTH 2X THE NUMBER OF POINTS. JUDGES: PLEASE MAKE SURE YOU APPLY THE MULTIPLIER WHEN ASSIGNING A FINAL SCORE.			
Technical Performance & Obstacle Course (X2)	Completed Obstacle 1 Points: _____ Time: _____ Points for tasks completed: Up to 20 points (points doubled if driver's view of course is obstructed by a blind or scrim at teams request). Time recorded in the event of a tie.	Completed Obstacle 2 Points: _____ Time: _____ Points for tasks completed: Up to 20 points (points doubled if driver's view of course is obstructed by a blind or scrim, at teams request). Time recorded in the event of a tie.	* Optional Autonomous Operation Points: _____ Time: _____ Points for tasks completed: Minimum of 5 points will be awarded for autonomous operation, all points for completed tasks will be doubled.
Rules violations (a deduction of 20% of the total possible points) must be initiated by the evaluator, coordinator and manager of the event. Record the deduction in the space to the right. Indicate the rule violated: _____			
(To arrive at the TOTAL score, add any subtotals and subtract rules violation points, as necessary.)			TOTAL SCORE

Comments:

I certify these results to be true and accurate to the best of my knowledge.

Evaluator:	Signature:
Printed name:	



Event Summaries - Middle School

The following descriptions are only brief summaries about the events available to middle school students. For detailed information about each of the national events, please consult the official Middle School National TSA Conference Competitive Events Guide. State-only event rules are detailed earlier in this guide. Please be sure to carefully read the event descriptions, regulations and procedures as some events have had updates and changes!

IMPORTANT: Several events have EARLY ELECTRONIC SUBMISSION deadlines. Events which have early submission deadlines are noted in these summaries. For those events, unless otherwise stated, contestants are to submit a single, multi-page PDF document containing all required documentation, related links (for example, links to games, or downloadable files, for example), and contest entries (like Pin and T-Shirt designs) via the COTSA State Conference Early Submission Entry Form located at: <http://goo.gl/hwsZvG> by 11:59 p.m. February 1, 2017. Contestants will need to enter their STATE CONFERENCE ID# when submitting their entries. Entries for events which have early submission deadlines that are not submitted electronically or are not received by the deadline will NOT be considered for competition.

For multimedia and video early submissions, entries will be required to be uploaded to YouTube on an unlisted channel and the URL (along with required documentation in PDF format) is to be submitted via the COTSA State Conference Early Submission Entry Form located at: <http://goo.gl/hwsZvG> by 11:59 p.m. February 1, 2017. Contestants will need to enter their STATE CONFERENCE ID# when submitting their entries. Entries for events which have early submission deadlines that are not submitted electronically or are not received by the deadline will NOT be considered for competition.

Be aware that contest updates and clarifications may occur throughout the school year and are available at: <http://www.tsaweb.org/Updates-and-Clarification>. Advisors and students are urged to check this site periodically throughout the year to prevent a disqualification at the state or national conferences! Themes for the various events are available at: <http://www.tsaweb.org/Themes-and-Problems>.

****NOTE: With each event, you will find the number of entries allowed. This number of entries is only applicable to the Colorado TSA State Conference; the number of entries permitted at the National TSA Conference are listed in the National TSA Competitive Events Guide.**



MIDDLE SCHOOL NATIONAL EVENTS

Biotechnology

Participants conduct research on a contemporary biotechnology issue of their choosing, document their research (student-performed research or a re-creation or simulation of research performed by the scientific community), and create a display. If appropriate, a model or prototype depicting an aspect of the issue may be included in the display. Finalist teams create a presentation and are interviewed about their topic.

Limited at State to: Three (3) teams of two (2) to six (6) students per chapter.

CAD Foundations

Participants in this event have the opportunity to demonstrate their understanding of CAD fundamentals as they create a two-dimensional graphic representation of an engineering part or object. (Examples might include a machine part, tool, device, or manufactured product.)

Limited at State to: Two (2) students per chapter.

Career Prep

Participants conduct research on a selected technology-related career and use this knowledge to prepare a letter of introduction and a chronological skills resume. Finalists participate in a mock interview. In 2017, students choose one (1) of these careers: Environmental Engineer, Cloud Infrastructure Architect, Bioengineer, or Computer Repair Technician. ***NOTE: Due to the complexity and the large number of entries in this event as well as the limited duration of the state conference, this event has an early submission deadline! Contestants should submit resume, letters and related materials as a single multi-page PDF file via our upload form located at: <http://goo.gl/hwsZvG> by 11:59 p.m. on February 1, 2017. Contestants will need to enter their STATE CONFERENCE ID# when submitting their entry. Entries not submitted electronically or are not received by the deadline will NOT be considered for competition.***

Limited at State to: Limited to one (1) entry per student.

Catapult Design

Participants design and produce a working catapult, within specified guidelines, that is adjustable and propels hollow plastic practice golf balls (weighing about 14.5 grams each) at a scoring target between 15' and 25' away.

Limited at State to Three (3) teams of two to four (2-4) students per chapter.

Challenging Technology Issues

Team members work together to prepare and deliver an extemporaneous, debate-style presentation with participants explaining opposing views of a current technology issue. The issue is randomly selected on site.

Limited at State to: Three (3) teams of two (2) per chapter.



Chapter Team

Participants take a written parliamentary procedures test in order to qualify for the semifinals, where they perform an opening ceremony, dispose of three (3) items of business, and perform a closing ceremony within a specified time period.

Limited at State to: One (1) team of six (6) per chapter.

Children's Stories

A team creates an illustrated children's story that will incorporate educational and social values. The story may be written in a genre of choice. Examples are fables, adventures, non-fiction, fiction, and fairy tales. The story must revolve around the theme chosen for the given year. For 2017, the theme is "The History of Technology." Finalists will be given up to twelve (12) minutes to read their stories and share their illustrations with judges, and an additional five (5) minutes to answer judges' questions. **NOTE: Due to the complexity and the large number of entries in this event as well as the limited duration of the state conference, this event has an early submission deadline! Contestants should submit entry as a single multi-page PDF file via the COTSA State Conference Early Submission Entry Form located at: <http://goo.gl/hwsZvG> by 11:59 p.m. on February 1, 2017. Contestants will need to enter their STATE CONFERENCE ID# when submitting their entry. Entries not submitted electronically or are not received by the deadline will NOT be considered for competition.**

Limited at State to: Three (3) teams of one to six (1-6) students per chapter. Finalist teams will have two (2) of those team members make the final presentation.

Community Service Video

Participants create and submit a video that depicts the local TSA chapter's service with the American Cancer Society (ACS), national TSA's community service partner. **NOTE: Due to the complexity and the large number of entries in this event as well as the limited duration of the state conference, this event has an early submission deadline! Contestants should upload the entry to YouTube as an UNLISTED video (as an unlisted video, the video will not appear in any of YouTube's public spaces such as search results, your channel, or the Browse page. Only people with whom you share the link will be able to view it). Once the video is uploaded, go to the COTSA Early Submission form located at: <http://goo.gl/hwsZvG> and submit the URL (along with required documentation in PDF format). All entries must be received by 11:59 p.m. on February 1, 2017. Contestants will need to enter their STATE CONFERENCE ID# when submitting their entry. Entries not submitted electronically or are not received by the deadline will NOT be considered for competition.**

Limited at State to: One (1) entry per chapter with no more than six (6) students per entry.

Construction Challenge

Participants identify a community need related to construction and then plan and implement a course of action that involves students and community members.

Limited at State to: Three (3) teams of two (2) per chapter.



Digital Photography

Participants produce a digital album consisting of color or black and white digital photographs that represent or relate to a chosen theme and place the album on a storage device for submission. Finalists produce a series of digital photographs taken at the conference site and edited appropriately for the on-site task. The theme for 2017 is “Standing Out From the Crowd.” **NOTE: Due to the complexity and the large number of entries in this event as well as the limited duration of the state conference, this event has an early submission deadline! Contestants should upload the entry as a single, multi-page PDF document via the COTSA State Conference Early Submission Entry Form located at: <http://goo.gl/hwsZvG>. All entries must be received by 11:59 p.m. on February 1, 2017. Contestants will need to enter their STATE CONFERENCE ID# when submitting your entry. Entries that are not submitted electronically or are not received by the deadline will NOT be considered for competition.**
Limited at State to: Two (2) students per chapter.

Dragster

Participants design, produce working drawings for and build a CO₂-powered dragster.
Limited at State to: Three (3) students per chapter.

Electrical Applications

Participants take a written test of basic electrical and electronic theory to qualify as finalists. Finalists assemble a specific circuit from a schematic diagram using a provided kit and make required electrical measurements. Finalists explain their solution during an interview.
Limited at State to: Three (3) students per chapter.

Environmental Engineering

Participants conduct research on the environmental engineering topic posted on the TSA website at: <http://www.tsaweb.org> under Competitions/Themes and Problems, document their research, and develop a multimedia presentation on the topic. Finalists create a presentation and will be interviewed. For 2017, the theme is: “Hydraulic Fracturing.” **NOTE: Due to the complexity and the large number of entries in this event as well as the limited duration of the state conference, this event has an early submission deadline! Contestants should submit their portfolio and multimedia presentation as a single zipped (.zip) or similar compressed file via the COTSA State Conference Early Submission Entry Form located at: <http://goo.gl/hwsZvG> and submit the entry, providing the link to the video in the space provided. All entries must be received by 11:59 p.m. on February 1, 2017. Contestants will need to enter their STATE CONFERENCE ID# when submitting their entry. Entries that are not submitted electronically or are not received by the deadline will NOT be considered for competition.**
Limited at State to: One (1) team per chapter (up to 6 students), but limited to 2-3 student representatives for finalist interview.



Essays on Technology

Participants conduct research in specified subtopics of a broader technological area and, using the knowledge and resources gained through that research, write an outline on the one (1) subtopic that is designated on site. Finalists write an essay on-site. The topic for the 2017 conference focuses on unmanned aerial vehicles (UAVs), including how they work, what role they may play in the future, uses of them in personal, business and government applications, and the registration of UAVs, including the need, penalties and controversies.

Limited at State to: Three (3) individuals per chapter.

Flight

Participants study the principles of flight and design in order to fabricate a glider that stays in flight for the greatest elapsed time. The glider must be designed to be launched from a catapult that is provided on site. The design process is documented in a portfolio that is submitted for evaluation.

Limited at State to: Six (6) students per chapter.

Forensic Technology

Participants take a written test of basic forensic science theory to qualify as finalists. Finalists demonstrate their ability to use forensic technology and skills to collect from and analyze a mock crime scene.

Limited at State to: One (1) team of two (2) individuals per chapter.

Geospatial Technology

Based on a design brief provided by TSA, participants develop a notebook containing maps, data, and appropriate documentation. Semifinalists make a presentation for an on-site problem that demonstrates their abilities to use geospatial data to develop solutions to environmental and social issues. The 2017 design brief is located on the national TSA website under Themes & Problems (<http://www.tsaweb.org/Themes-and-Problems>).

Limited at State to: One (1) team of two (2) to five (5) members per chapter.

Inventions and Innovations

Teams investigate and determine the need for an invention or innovation of a device, system, or process and then brainstorm ideas for a possible solution. Team entries must include documentation of the team's work; a display; and a model/prototype. Finalists make an oral presentation to a panel of evaluators (who act as venture capital investors) to persuade the panel to invest in their invention/innovation. Evaluators interview the participants.

Limited at State to: Three (3) teams of three (3) to six (6) individuals per chapter.

Junior Solar Sprint

Participants demonstrate their knowledge of science, technology, engineering, and mathematics (STEM) concepts, creativity, teamwork, and problem-solving skills as they design, construct and race a solar-powered car.

Limited at State to: One (1) team of two (2) to four (4) students per chapter.



Leadership Strategies

Participants demonstrate leadership and team skills by preparing a presentation based on challenges that officers of a TSA chapter might encounter.

Limited at State to: Three (3) teams of three (3) per chapter.

Mass Production

Participants manufacture a marketable product related to the current year's theme, noted on the TSA website (<http://www.tsaweb.org>) under Competitions/Themes and Problems. The team submits a documentation portfolio of the activities and the product—three (3) identical—made during the manufacturing process. For 2017, the theme is: Creating and producing a charging station for phones or tablets.

Limited at State to: One (1) team of two (2) to six (6) students per chapter. Two (2) members of a team must be present at a finalist presentation/interview.

Medical Technology Issues

Participants conduct research on a contemporary medical technology issue of their choosing, document their research and solution, and create a display. The entry may include student research or a re-creation or simulation of research performed by the scientific community. If appropriate, a model or prototype depicting an aspect of the issue may be included in the display. Finalists give a presentation.

Limited at State to: Three (3) teams of two (2) to six (6) individuals per chapter.

Microcontroller Design

Teams develop a working digital device (product) with real-world applications. Through a multimedia presentation, product demonstration, and documentation, the team demonstrates in detail its knowledge of microcontroller programming, simple circuitry, and product design and marketing. The project should have educational and/or social value and conform to the theme for the year. The theme will be posted on the TSA website (<http://www.tsaweb.org>) under Competitions/Themes and Problems. Teams demonstrate and promote their work in a timed presentation. For 2017, the theme is: Create a product (example: a moisture or air quality sensor) that monitors and reports on environmental conditions

Limited at State to: One (1) team of three to five (3-5) members per chapter. Up to three (3) team members may participate in the presentation.

Prepared Speech

Participant delivers a speech that reflects the theme of the current national TSA conference. The theme for 2017 is: Defining Your Future.

Limited at State to: Three (3) students per chapter.



Problem Solving

Participants must work effectively as a team to manipulate and process materials using only the tools designated. An objective measurement is used to determine the best solution to the given problem.

Limited at State to: Two (2) teams of two (2) members per chapter.

Promotional Marketing

Participants design a three-part TSA Marketing Toolkit that must include a national conference promotional poster, a state delegation fact sheet, and a chapter t-shirt design; the toolkit must be submitted in digital PDF format. Finalists are asked to work creatively under constraints to design a solution to a problem given on site, using their own computer/laptop work station. **NOTE: Due to the complexity and the large number of entries in this event as well as the limited duration of the state conference, this event has an early submission deadline! Contestants should submit entry as a single, multi-page PDF file via the COTSA State Conference Early Submission Entry Form located at: <http://goo.gl/hwsZvG> by 11:59 p.m. on February 1, 2017. Contestants will need to enter their STATE CONFERENCE ID# when submitting their entry. Entries that are not submitted electronically or are not received by the deadline will NOT be considered for competition.**

Limited at State to: Six (6) students per chapter.

STEM Animation

Participants use computer graphics tools and design processes (i.e., animation) to communicate, inform, analyze and/or illustrate a topic, idea, subject, or concept that focuses on one (1) or more of the following areas: science, technology, engineering, and/or mathematics; sound may accompany graphic images. **NOTE: Due to the complexity and the large number of entries in this event as well as the limited duration of the state conference, this event has an early submission deadline! Contestants should upload the entry to YouTube as an UNLISTED video (as an unlisted video, the video will not appear in any of YouTube's public spaces such as search results, a person's channel, or the Browse page. Only people with whom the link is shared will be able to view it). Once the video is uploaded, go to the COTSA State Conference Early Submission Entry Form located at: <http://goo.gl/hwsZvG> and submit the URL to the video (along with required documentation in PDF format). All entries must be received by 11:59 p.m. on February 1, 2017. Contestants will need to enter their STATE CONFERENCE ID# when submitting your entry. Entries that are not submitted electronically or are not received by the deadline will NOT be considered for competition.**

Limited at State to: Six (6) teams of one to six (1-6) students per chapter, one (1) entry per team.



Structural Engineering

Teams apply the principles of structural design and engineering through basic research, design, construction, and destructive testing to determine the design efficiency of a structure. Details about the structure and information related to it will be posted on the TSA website at <http://www.tsaweb.org>, under Competitions/Themes and Problems. The on-site finalist problem will be a variation of the pre-conference problem posted on the TSA website.

Limited at State to: Two (2) teams of two (2) per chapter.

System Control Technology

Participants use a team approach to develop a computer-controlled model solution to a given problem, typically one based on an industrial setting. Teams analyze the problem, build a computer-controlled mechanical model, program the model, explain the program and mechanical features of the model-solution, and leave instructions for evaluators to operate the device.

Limited at State to: One (1) team of three (3) per chapter.

Tech Bowl

A team of three (3) students complete a written test and then compete in a head-to-head competition similar to “Jeopardy” where students “buzz-in” and answer technical questions orally. The competition will be CLOSED to observers.

Limited at State to: One (1) team of three (3) per chapter.

Technical Design

Participants demonstrate their ability to use the technical design process to solve an engineering design problem on site at the conference.

Limited at State to: Two (2) teams of two (2) individuals per chapter.

Video Game Design

Participants develop, build, and launch an E-rated, online game that focuses on the subject of their choice. The game should be interesting, exciting, visually appealing, and intellectually challenging. The game and all required documentation must be submitted-and will be evaluated online, pre-conference. Finalist teams (list posted at the conference) participate in an on-site interview to demonstrate the knowledge and expertise they gained during the development of the game. **NOTE: Due to the complexity and the large number of entries in this event as well as the limited duration of the state conference, this event has an early submission deadline! Contestants should upload the URL of the game via the COTSA State Conference Early Submission Entry Form located at: <http://goo.gl/hwsZvG>. Contestants should provide the URL in the space provided and upload the documentation portfolio in a single, multi-page PDF document. All entries must be received by 11:59 p.m. on February 1, 2017. Contestants will need to enter their STATE CONFERENCE ID# when submitting their entry. Entries that are not submitted electronically or are not received by the deadline will NOT be considered for competition.**

Limited at State to: One (1) team of two (2) to six (6) students per chapter.



Website Design

Participants are required to design, build, and launch a website that features the team's ability to incorporate the elements of website design, graphic layout, and proper coding techniques. The design brief for the website will be posted on the TSA website at <http://www.tsaweb.org> under Competitions/Themes and Problems. Finalists (posted at the conference) participate in an on-site conference interview to demonstrate the knowledge and expertise gained during the development of the website, with an emphasis on web design as it pertains to their solution. **NOTE: Due to the complexity and the large number of entries in this event as well as the limited duration of the state conference, this event has an early submission deadline! Contestants should submit the URL (which points to the main page of the team's entry) via the COTSA State Conference Early Submission Entry Form located at: <http://goo.gl/hwsZvG> no later than 11:59 p.m. on February 1, 2017. After 11:59 p.m. on February 1 changes should not be made to the website. If the team makes changes or updates to the website after the evaluators begin judging the entry, those changes will not be considered. Contestants will need to enter their STATE CONFERENCE ID# when submitting their entry. Entries that are not submitted electronically or are not received by the deadline will NOT be considered for competition.**

Limited at State to: One (1) team of three (3) to six (6) members per chapter. One (1) entry per team is permitted. Up to six (6) members of a team participate in the interview.

MIDDLE SCHOOL STATE-ONLY EVENTS

Crash Test

Teams consisting of a middle school student and an elementary student design and build a "crash test" car that will be tested in multiple head-on and rear-end collisions. The theme for 2016-17 is: Emergency Vehicle.

Limited to: Ten (10) teams of two (2) students per chapter. Each team MUST include one (1) MS and one (1) Elementary student (grades 1-5).

Fashion Design (**NEW EVENT!**)

Students have the opportunity to research, develop, and create garment designs, garment mock-ups, and portfolios that reflect the current year's published theme. At the state competition, teams participate in an on-site event in which they present their potential designs to the judges and an audience. For 2017, the theme is wedding fashions from around the world.

Limited at State to: Two (2) teams of two to four (2-4) students per chapter.

Giant Jenga Tournament

Teams take turns in this bracketed-tournament competition to build the tallest structure possible without tipping it over.

Limited at State to: Four (4) teams of two to four (2-4) students per chapter. NOTE: This event does not earn medals or points for a school toward the Chapter of the Year award. Winners of this event are awarded the traveling Giant Jenga Trophy.



Integrated Autonomous Vehicle

Participants create and operate an integrated autonomous vehicle. The vehicle will operate in a number of courses, but must be able to navigate a course without prior knowledge of distance or direction within a chosen course. Two separate modes of operation will be used: Student-controlled and Autonomous. **NOTE: Due to the complexity and the large number of entries in this event as well as the limited duration of the state conference, this event has an early submission deadline! Contestants should submit a link to the project's technical documentation via the COTSA State Conference Early Submission Entry Form located at: <http://goo.gl/hwsZvG> by 11:59 p.m. on February 1, 2017. Contestants will need to enter their STATE CONFERENCE ID# when submitting your entry. Entries that are not submitted electronically or are not received by the deadline will NOT be considered for competition.**

Limited to: Two (2) teams of three (3) members per chapter.

Middle School Creativity Challenge

Design teams, composed of one middle school student and one elementary student, work to solve an on-site problem.

Limited to: Ten (10) teams of two (2) students per chapter. Each team MUST include one (1) MS and one (1) Elementary student (grades 1-6* See rules for more information).

Mousetrap Tractor Pull

Participants design, build and test a model vehicle powered only by a standard mousetrap. The vehicle is tested by having it pull as much weight as possible over a set distance.

Limited to: Six (6) students per chapter.

On Demand Video (NEW EVENT!)

Participants write, shoot, and edit a short video during the conference in this on-site event. Required criteria, such as props and a line of dialogue, make the competition more challenging and will be revealed at the event orientation meeting. NOTE: Due to the length of the state conference, this event will be shortened at state to fit within the allotted time.

Limited at State to: One (1) team of two to six (2-6) students per chapter.

Pin Design

Participants design a lapel pin representative of Colorado and Colorado TSA to be used for trading at the National TSA Conference. The winning middle school and winning high school designs will be made into pins for trading. **NOTE: Due to the complexity and the large number of entries in this event as well as the limited duration of the state conference, this event has an early submission deadline! Contestants should submit entry as a single, multi-page PDF file via the COTSA State Conference Early Submission Entry Form located at: <http://goo.gl/hwsZvG> by 11:59 p.m. on February 1, 2017. Contestants will need to enter their STATE CONFERENCE ID# when submitting your entry. Entries that are not submitted electronically or are not received by the deadline will NOT be considered for competition.**

Limited to: One (1) entry per student.



Rubber Band Powered Car

Participants design, build and then race a rubber band-powered propeller car that resembles a commercially produced automobile.

Limited to: Three (3) students per chapter.

Silent Movie (NEW EVENT!)

Participants demonstrate their abilities and skills in the field of music and digital video production to create a “silent movie” and then create a musical score to accompany the film.

Limited at State to: One (1) team of two to six (2-6) students per chapter.

T-Shirt Design

Participants design the Colorado delegation’s national conference T-shirt. The winner between the middle and high school top finishers will become the state delegation T-shirt. **NOTE: Due to the complexity and the large number of entries in this event as well as the limited duration of the state conference, this event has an early submission deadline! Contestants should submit entry as a single, multi-page PDF file via the COTSA State Conference Early Submission Entry Form located at: <http://goo.gl/hwsZvG> by 11:59 p.m. on February 1, 2017. Contestants will need to enter their STATE CONFERENCE ID# when submitting your entry. Entries that are not submitted electronically or are not received by the deadline will NOT be considered for competition.**

Limited to: One (1) entry per student.

Underwater ROV Challenge

Participants apply and document the engineering design process, mathematical principles and scientific concepts used in the research, design, construction, testing and evaluation of an underwater remote operated vehicle (ROV). The ROV will be expected to perform a range of tasks including: passing through one or more rings, and then backing through the same route; retrieving rings from the bottom of the testing tank/pool; entering and illuminating a cave area; and/or demonstrating full maneuverability in three axes of motion.

Limited to: Two (2) teams of 2 (two) to six (6) students per chapter.



Event Summaries - High School

The following descriptions are only brief summaries about the events available to students. For detailed information about each of the national events, please consult the official High School National TSA Conference Competitive Events Guide. State-only event rules are detailed earlier in this guide. Please be sure to carefully read the event descriptions, regulations and procedures!

IMPORTANT UPDATE: *Several events have EARLY ELECTRONIC SUBMISSION deadlines. Events which have early submission deadlines are noted in these summaries. For those events, unless otherwise stated, contestants are to submit a single, multi-page PDF document containing all required documentation, related links (to download videos or game files, for example), and contest entries (like Pin and T-Shirt designs) via the COTSA State Conference Early Submission Entry Form located at: <http://goo.gl/hwsZvG> by 11:59 p.m. on February 1, 2017. Contestants will need to enter their STATE CONFERENCE ID# when submitting their entry. Entries not submitted electronically or are not received by the deadline will NOT be considered for competition.*

For multimedia and video early submissions, entries will be required to be uploaded to YouTube on an unlisted channel and the URL (along with required documentation in PDF format) is to be submitted via the COTSA State Conference Early Submission Entry Form located at: <http://goo.gl/hwsZvG> by 11:59 p.m. on February 1, 2017. Contestants will need to enter their STATE CONFERENCE ID# when submitting their entries. Entries for events which have early submission deadlines that are not submitted electronically or are not received by the deadline will NOT be considered for competition.

Be aware that contest updates and clarifications may occur throughout the school year and are available at: <http://www.tsaweb.org/Updates-and-Clarification>. Advisors and students are urged to check this site periodically throughout the year to prevent a disqualification at the state or national conferences! Themes for the various events are available on the National TSA website at <http://www.tsaweb.org/Themes-and-Problems>.

****NOTE:** *With each event, you will find the number of entries allowed. This number of entries is only applicable to the Colorado TSA State Conference; the number of entries permitted at the National TSA Conference are listed in the National TSA Competitive Events Guide.*



HIGH SCHOOL NATIONAL EVENTS

3D Animation (NEW EVENT!)

Participants demonstrate their knowledge of 3D animation technology and design skills to creatively solve the challenge posted on the national TSA website. Semifinalists participate in an on-site competition in which they further demonstrate their 3D design skills and proficiency in 3D animation technology. **NOTE: Due to the complexity and the large number of entries in this event as well as the limited duration of the state conference, this event has an early submission deadline! Contestants should upload the animation to YouTube as an UNLISTED video (as an unlisted video, the video will not appear in any of YouTube's public spaces such as search results, a person's channel, or the Browse page. Only people with whom the link is shared will be able to view it). Once the video is uploaded, go to the COTSA State Conference Early Submission Entry Form located at: <http://goo.gl/hwsZvG> and submit the entry, providing the URL in the space provided. Any accompanying documentation should also be uploaded as a single, multi-page PDF file at that time. All entries must be received by 11:59 p.m. on February 1, 2017. Contestants will need to enter their STATE CONFERENCE ID# when submitting their entry. Entries not submitted electronically or are not received by the deadline will NOT be considered for competition.**

Limited at State to: Three (3) teams of two (2) individuals per chapter.

Animatronics

Participants work as a team to demonstrate knowledge of mechanical and control systems by designing, fabricating, and controlling an animatronics device that will communicate, entertain, inform, demonstrate and/or illustrate a topic, idea, subject or concept. Sound, lights and surrounding environment are to accompany the device. For 2017, the theme is to create an animatronic device for an exhibit at a children's museum.

Limited at State to: Two (2) teams of two to six (2-6) individuals per chapter with a limit of three (3) representatives per team for the presentation/interview.

Architectural Design (NEW NAME!)

Participants develop a set of architectural plans and related materials for an annual architectural renovation design challenge and construct a physical as well as computer-generated model to accurately depict their design.

Limited at State to: Three (3) teams of one to six (1-6) students per chapter.

Biotechnology Design

Participants select a contemporary biotechnology problem that relates to the current year's published area of focus and demonstrate understanding of it through documented research, the development of a solution, a display, and an effective multimedia presentation. If appropriate, a model or prototype of the solution may be included in the display. Participants may choose to recreate or simulate research that previously has been performed within the scientific community. For 2017, the theme is: Vaccines.

Limited at State to: Three (3) teams of two to six (2-6) members per team with a limit of two (2) representatives per team for the finalist presentation.



Chapter Team

Participants take a written parliamentary procedures test in order to qualify for the semifinals, where they perform an opening ceremony, dispose of items of business, and perform a closing ceremony within a specified time period.

Limited at State to: One (1) team of six (6) per chapter.

Children's Stories

Participants create an illustrated children's story of high artistic, instructional, and social value. The story may be written in prose or poetry and take the form of a fable, adventure story, or other structure. For 2017, participants will also construct a hard-bound pop-up book where the pop-ups illustrate the story.

Limited at State to: Three (3) teams of one to six (1-6) students per chapter. Finalist teams will have two (2) of those team members make the final presentation.

Coding

Participants respond to an annual coding-related design challenge by developing a software program that will accurately address an on-site problem in a specified, limited amount of time. Specific elements to be used, such as the programming language, operating system, or application programming interface (API), will be released on-site. Completed solutions will be objectively measured to determine the best and most effective solution for the stated problem.

Limited at State to: Two (2) teams of one to three (1-3) members per chapter.

Computer Aided Design - Architecture (**NEW NAME!**)

Participants create representations, such as foundation and/or floor plans, and/or elevation drawings, and/or details of architectural ornamentation or cabinetry. Participants may compete in CAD - Architecture or CAD - Engineering, but not both. **NOTE: Due to the complexity and the large number of entries in this event as well as the limited duration of the state conference, contestants will participate in a preliminary round at the state the conference to determine finalists. Finalists will then compete in a 2.5 hour-long on-site challenge. Please plan appropriately when preparing for this event.**

Limited at State to: Three (3) students per chapter with only one (1) CAD event per student.

Computer Aided Design - Engineering (**NEW NAME!**)

Participants create a 3D computer model(s) of an engineering or machine object, such as a machine part, tool, device, or manufactured product. Participants may compete in CAD - Architecture or CAD - Engineering, but not both. **NOTE: Due to the complexity and the large number of entries in this event as well as the limited duration of the state conference, contestants will participate in a preliminary round at the state conference to determine finalists. Finalists will then compete in a 2.5 hour-long on-site challenge. Please plan appropriately when preparing for this event.**

Limited at State to: Three (3) students per chapter with only one (1) CAD event per student.



Computer Integrated Manufacturing (*NEW EVENT!*)

Participants design, fabricate, and use Computer Integrated Manufacturing (CIM) to create a promotional TSA product that will showcase the current conference city and/or state. The product may use additive and/or subtractive manufacturing of any traditional, Computer Numerical Control (CNC), 3D printing, or laser technology available. Documentation, one completed sample, and one set of manufactured parts are checked in and evaluated. Semifinalist teams assemble their entry and give a live promotional sales pitch to judges.

Limited at State to: Three (3) teams of two (2) individuals per chapter

Debating Technological Issues

Team members work together to prepare for a debate against a team from another chapter. The teams will be instructed to take either the pro or con side of the designated topic.

Limited at State to: One (1) team of two (2) members per chapter.

Digital Video Production

Participants develop a digital video/film that focuses on the given year's theme. Sound may accompany the film. For 2017, the theme is: Digital Citizenship. **NOTE: Due to the complexity and the large number of entries in this event as well as the limited duration of the state conference, this event has an early submission deadline! Contestants should upload the entry to YouTube as an UNLISTED video (as an unlisted video, the video will not appear in any of YouTube's public spaces such as search results, a person's channel, or the Browse page. Only people with whom the link is shared will be able to view it). Once the video is uploaded, go to the COTSA State Conference Early Submission Entry Form located at: <http://goo.gl/hwsZvG> and submit the entry, providing the URL in the space provided. All entries must be received by 11:59 p.m. on February 1, 2017. Contestants will need to enter their STATE CONFERENCE ID# when submitting their entry. Entries not submitted electronically or are not received by the deadline will NOT be considered for competition.**

Limited at State to: Three (3) teams of two (2) to six (6) students per chapter.

Dragster Design

Participants design, produce working drawings for, and build a CO₂- powered dragster.

Limited at State to: Three (3) students per chapter.

Engineering Design

The National Academy of Engineering has identified fourteen (14) paramount current and emerging societal challenges that engineering can play a major role in solving. Through research and critical problem-solving, teams will develop a solution to a grand challenge posted on the national TSA website under Competition Themes/Problems. The solution offered will be informed and designed by precise problem definition, thorough research, creativity, experimentation (when possible), and the development of documents and appropriate models (mathematical, graphical, and/or physical prototype/model). Semifinalist teams will present and defend their proposed solution to a panel of evaluators. The semifinalist presentation will be in the format of a poster session (the poster will be contained in a display). For 2017, the theme is: Providing Access to Clean Water.

Limited at State to: Three (3) teams of three to six (3-6) people per chapter.



Essays on Technology (*REVISED!*)

Participants will write a research-based essay using two (2) or more sources provided on-site, that makes insightful connections about a current technological topic. Participants are required to bring and use a laptop computer to prepare the essays.

Limited at State to: Three (3) students per chapter.

Extemporaneous Presentation

Participants give a three to five (3-5) minute speech fifteen (15) minutes after having drawn a card on which a technology or TSA topic for their speech is written.

Limited at State to: Three (3) students per chapter.

Fashion Design & Technology (*NEW NAME!*)

Students have the opportunity to research, develop, and create garment designs, garment mock-ups, and portfolios that reflect the current year's published theme. At the state competition, teams participate in an on-site event in which they present their potential garment designs to the judges on a TSA runway. For 2017, the theme focuses on recycling in fashion. Teams must use recycled materials to design and create a total of three different prototypes (garments).

Limited at State to: Two (2) teams of two to four (2-4) students per chapter.

Flight Endurance

Participants analyze flight principles with a rubber band-powered model aircraft. Participants have the opportunity to build, fly, and adjust (trim) a model to make long endurance flights inside a contained airspace. Models must be of fixed-wing design and comply with all event specifications. Rotary-wing aircraft and aerostat (lighter than air) aircraft are NOT permitted.

Limited at State to: Three (3) students per chapter.

Future Technology Teacher

While the need for student proficiency in technology (as one area of STEM) is increasing, the number of qualified technology education teachers is decreasing. To help address this imbalance, this event will encourage participants to 1) investigate technology education preparation programs in higher education, and 2) test their potential as a future technology educator. **NOTE: Due to the complexity and the large number of entries in this event as well as the limited duration of the state conference, this event has an early submission deadline! Contestants should submit entry as a single, multi-page PDF file via the COTSA State Conference Early Submission Entry Form located at: <http://goo.gl/hwsZvG> by 11:59 p.m. on February 1, 2017. Contestants will need to enter their STATE CONFERENCE ID# when submitting their entry. Entries not submitted electronically or are not received by the deadline will NOT be considered for competition.**

Limited at State to: Three (3) students per chapter.



Music Production

Participants produce an original musical piece that is designed to be played during the national TSA conference opening or closing general sessions. The musical piece should be energizing, interesting and of a spirit consistent with the Technology Student Association. **NOTE: Due to the complexity and the large number of entries in this event as well as the limited duration of the state conference, this event has an early submission deadline! Contestants should upload the entry as an .mp3 or .wav file via the COTSA State Conference Early Submission Entry Form located at: <http://goo.gl/hwsZvG> by 11:59 p.m. on February 1, 2017. Any accompanying documentation should also be uploaded as a single, multi-page PDF file at that time. Contestants will need to enter their STATE CONFERENCE ID# when submitting their entry. Entries not submitted electronically or are not received by the deadline will NOT be considered for competition.**

Limited at State to: Six (6) teams of one to six (1-6) students per chapter.

On Demand Video

Participants write, shoot, and edit a short video during the conference in this on-site event. Required criteria, such as props and a line of dialogue, make the competition more challenging and will be revealed at the event orientation meeting. NOTE: Due to the length of the state conference, this event will be shortened at state to fit within the allotted time.

Limited at State to: One (1) team of two to six (2-6) students per chapter.

Photographic Technology (REVISED!)

Participants have the opportunity to demonstrate understanding of and expertise in using photographic and imaging technology processes to convey a message. Participants produce a portfolio of five (5) powerful images focusing on the given theme. Semifinalists record images and then utilize graphic editing software to prepare a single final image as a solution to an on-site prompt. For 2017, the theme is: Humor. **NOTE: Due to the complexity and the large number of entries in this event as well as the limited duration of the state conference, this event has an early submission deadline! Contestants should upload the entry as a single, multi-page PDF document via the COTSA State Conference Early Submission Entry Form located at: <http://goo.gl/hwsZvG>. All entries must be received by 11:59 p.m. on February 1, 2017. Contestants will need to enter their STATE CONFERENCE ID# when submitting your entry. Entries that are not submitted electronically or are not received by the deadline will NOT be considered for competition.**

Limited at State to: Two (2) students per chapter.



Prepared Presentation (*NEW EVENT!*)

Participants have the opportunity to develop and deliver an oral presentation using a digital slide deck on an assigned topic provided on-site.

Limited at State to: Three (3) students per chapter.

Promotional Design (*NEW EVENT!*)

Participants have the opportunity to use computerized graphic communications layout and design skills in the production of a promotional resource for TSA. Participants produce an original multi-piece marketing portfolio to be used for TSA chapter recruitment, or as an introductory packet for new TSA advisors/teachers. This promotional packet would be mailable and would include four to five (4-5) separate and different items. The packet must provide details about TSA, its history, its co-curricular relationship with Engineering and Technology pathway courses, its membership guidelines and instructions for joining, the competitive events program, signature events, service projects, STEM connections, leadership training activities, and sample chapter membership recruitment items. Portfolio examples might include: a pamphlet, post card, letter, small poster, business card, and a PDF of a color graphic for branding promotional gifts. The complete portfolio must demonstrate a unity of design that repeats throughout the included items. Semifinalists respond to an on-site problem with a solution that demonstrates their ability to use a computer to design and edit materials for in-house publication. **NOTE: Due to the complexity and the large number of entries in this event as well as the limited duration of the state conference, this event has an early submission deadline! Contestants should upload the entry as PDF document via the COTSA State Conference Early Submission Entry Form located at: <http://goo.gl/hwsZvG>. All entries must be received by 11:59 p.m. on February 1, 2017. Contestants will need to enter their STATE CONFERENCE ID# when submitting their entry. Entries not submitted electronically or are not received by the deadline will NOT be considered for competition.**

Limited at State to: Six (6) individuals per chapter.

SciVis

Scientific and Technical Visualization (SciVis) is the representation of complex scientific and/or technical concepts in a visual form. Participants use either 2D or 3D computer graphics tools and design processes to communicate, inform, analyze, and/or illustrate a STEM topic, idea, subject, or concept. **NOTE: Due to the complexity and the large number of entries in this event as well as the limited duration of the state conference, this event has an early submission deadline! Contestants should upload the entry to YouTube as an UNLISTED video (as an unlisted video, the video will not appear in any of YouTube's public spaces such as search results, a person's channel, or the Browse page. Only people with whom the link is shared will be able to view it). Once the video is uploaded, go to the COTSA State Conference Early Submission Entry Form located at: <http://goo.gl/hwsZvG> and submit the entry, providing the link to the visualization in the space provided. All entries must be received by 11:59 p.m. on February 1, 2017. Contestants will need to enter their STATE CONFERENCE ID# when submitting their entry. Entries not submitted electronically or are not received by the deadline will NOT be considered for competition.**

Limited at State to: Three (3) teams of one to six (1-6) students per chapter.



Software Development (**REVISED!**)

Participants have the opportunity to use knowledge of cutting-edge technologies, algorithm design, problem-solving principles, effective communication, and collaborative teamwork to design, implement, test, and document a software development project. The project should have educational or social value. **NOTE: Due to the complexity and the large number of entries in this event as well as the limited duration of the state conference, this event has an early submission deadline! Contestants should submit the documentation portfolio and related materials as a single multi-page PDF file via the COTSA State Conference Early Submission Entry Form located at: <http://goo.gl/hwsZvG> by 11:59 p.m. on February 1, 2017. Contestants will need to enter their STATE CONFERENCE ID# when submitting their entry. Entries not submitted electronically or are not received by the deadline will NOT be considered for competition. Only the documentation portfolio needs to be submitted early as all entries will present at the state conference. Contestants are to bring a working copy of their software on a computer capable of running the program to their presentation. Participants will demonstrate the program to the judges as part of the presentation.**

Limited at State to: One (1) team of two to six (2-6) students per chapter.

STEM Careers (**NEW EVENT!**)

During the school year, participants work to develop a specific skill and complete a thorough project about the skill's relationship to a STEM career area of their choice. Participants research and prepare documentation related to the skill and prepare a video that demonstrates the skill. Semifinalists participate in an on-site interview to discuss the skill developed. **NOTE: Due to the complexity and the large number of entries in this event as well as the limited duration of the state conference, this event has an early submission deadline! Contestants should upload the entry to YouTube as an UNLISTED video (as an unlisted video, the video will not appear in any of YouTube's public spaces such as search results, a person's channel, or the Browse page. Only people with whom the link is shared will be able to view it). Once the video is uploaded, go to the COTSA State Conference Early Submission Entry Form located at: <http://goo.gl/hwsZvG> and submit the entry, providing the URL in the space provided and including a single, multi-page PDF document containing any required documentation. All entries must be received by 11:59 p.m. on February 1, 2017. Contestants will need to enter their STATE CONFERENCE ID# when submitting their entry. Entries not submitted electronically or are not received by the deadline will NOT be considered for competition.**

Limited at State to: Six (6) entry per chapter.



Structural Design and Engineering

Participants work as a team to build a designated structure. Teams apply the principles of structural design and engineering through research, design, construction, destructive testing, and assessment to determine the design efficiency of the structure. Details about the structure and information related to it will be posted on the TSA website under Competitions/Themes and Problems. The on-site semifinalist problem will be a variation of the pre-conference problem posted on the TSA website. For 2017, participants must research bridge crane structures and develop a design for a bridge crane that meets the specifications of the design brief.

Limited at State to: Two (2) teams of two (2) students per chapter.

System Control Technology

Participants work as part of a team on site to develop a computer-controlled model-solution to a problem, typically one from an industrial setting. Teams analyze the problem, build a computer-controlled mechanical model, program the model, explain the program and mechanical features of the model-solution, and leave instructions for evaluators to operate the device.

Limited at State to: One (1) of three (3) students per chapter.

Technology Bowl

A written test followed by a knowledge bowl format like “Jeopardy” where students “buzz-in” and answer technical questions orally. The oral round will be CLOSED to observers at the state conference.

Limited at State to: One (1) team of three (3) students per chapter.

Technology Problem Solving

Participants work together to develop and create a solution to a problem using the limited materials provided and the tools allowed. Completed solutions will be objectively measured and judged to determine the best and most effective solution for the stated problem. Participants won’t know what this one is until they show up!

Limited at State to: Two (2) teams of two (2) students per chapter.

Transportation Modeling

Using only designated materials and following required specifications, participants research, design, and produce a scale model of a vehicle that fits the annual design problem, which is posted on the TSA website under Competitions/Themes and Problems. The entry must take appearance and realism into consideration. For 2017, the theme is: Motorcycles.

Limited at State to: Three (3) students per chapter.



Video Game Design (REVISED!)

Participants develop a game that focuses on the subject of their choice. The game must be interesting, exciting, visually appealing, and intellectually challenging. The game must have high artistic, educational, and social value. For 2017, participants focus on the idea of their choice, within the context of the theme: Arcade Games. **NOTE: Due to the complexity and the large number of entries in this event as well as the limited duration of the state conference, this event has an early submission deadline! Contestants should submit the documentation portfolio and related materials as a single multi-page PDF file via the COTSA State Conference Early Submission Entry Form located at: <http://goo.gl/hwsZvG> by 11:59 p.m. on February 1, 2017. Contestants will need to enter their STATE CONFERENCE ID# when submitting their entry. Entries not submitted electronically or are not received by the deadline will NOT be considered for competition. Only the documentation portfolio needs to be submitted by the early submission deadline. Representatives from each semifinalist team will then report to the event area at the time and place stated in the conference program, with the game pre-loaded and ready to play on their own laptop or computer, for an interview.**

Limited at State to: Two (2) teams of two to six (2-6) students per chapter.

Webmaster

Participants are required to design, build, and launch a website that features the school's career and technology/engineering program, the TSA chapter, and the chapter's ability to research and present a given topic pertaining to technology (referred to as the "design brief"). Conference semifinalists participate in an on-site interview to demonstrate the knowledge and expertise gained during the development of the website — with an emphasis on web design methods and practices, as well as their research for the annual design topic. For 2017, the topic is: Augmented Reality: Understanding the Potential Benefits and Challenges. **NOTE: Due to the complexity and the large number of entries in this event as well as the limited duration of the state conference, this event has an early submission deadline! Contestants should upload the URL (which points to the main page of the team's entry) via the COTSA State Conference Early Submission Entry Form located at: <http://goo.gl/hwsZvG> no later than 11:59 p.m. on February 1, 2017. After 11:59 p.m. on February 1 changes should not be made to the website. If the team makes changes or updates to the website after the evaluators begin judging the entry, those changes will not be considered. Contestants will need to enter their STATE CONFERENCE ID# when submitting their entry. Entries not submitted electronically or are not received by the deadline will NOT be considered for competition.**

Limited at State to: One (1) team of three to five (3-5) students per chapter.



HIGH SCHOOL STATE-ONLY EVENTS

Catapult Design

Participants design and produce a working catapult, within specified guidelines, that is adjustable and propels hollow plastic practice golf balls (weighing about 14.5 grams each) at a scoring target between 15' and 25' away.

Limited to: Three (3) teams of two to four (2-4) students per chapter.

Fore!

Teams, composed of one high school student and one elementary student, design and develop one hole for a proposed miniature golf course.

Limited to: Ten (10) teams of two (2) students per chapter. Each team MUST include one (1) HS and one (1) elementary student (grades 1-5).

Giant Jenga Tournament

Teams take turns in this bracketed-tournament competition to build the tallest structure possible without tipping it over.

Limited to: Four (4) teams of two to four (2-4) students per chapter. NOTE: This event does not earn medals or points for a school toward the Chapter of the Year award. Winners of this event are awarded the traveling Giant Jenga Trophy.

High School Creativity Challenge

Design teams, composed of one high school student and one elementary student, work to solve an on-site problem.

Limited to: Ten (10) teams of two (2) students per chapter. Each team MUST include one (1) HS and one (1) elementary student (grades 1-6* See rules for more information). NOTE: This is a non-competitive event and does not earn medals or points for a school toward the Chapter of the Year award.

Integrated Autonomous Vehicle

Participants create and operate an integrated autonomous vehicle. The vehicle will operate in a number of courses, but must be able to navigate a course without prior knowledge of distance or direction within a chosen course. Two separate modes of operation will be used: Student-controlled and Autonomous.

Limited to: Two (2) teams of three (3) members per chapter.



Pin Design

Participants design a lapel pin representative of Colorado and Colorado TSA to be used for trading at the National TSA Conference. The winning middle school and winning high school designs will be made into pins for trading. **NOTE: Due to the complexity and the large number of entries in this event as well as the limited duration of the state conference, this event has an early submission deadline! Contestants should submit entry as a single, multi-page PDF file via the COTSA State Conference Early Submission Entry Form located at: <http://goo.gl/hwsZvG> by 11:59 p.m. on February 1, 2017. Contestants will need to enter their STATE CONFERENCE ID# / TEAM ID# when submitting their entry. Entries that are not submitted electronically or are not received by the deadline will NOT be considered for competition.**

Limited to: One (1) entry per student.

Rat Trap Drag Race

Participants design and build a vehicle powered solely by a standard rat trap.

Limited to: Six (6) students per chapter.

Rubber Band Powered Car

Participants design, build and then race a rubber band-powered propeller car that resembles a commercially produced automobile.

Limited to: Three (3) students per chapter.

Silent Movie (**NEW EVENT!**)

Participants demonstrate their abilities and skills in the field of music and digital video production to create a “silent movie” and then create a musical score to accompany the film.

Limited at State to: One (1) team of two to six (2-6) students per chapter.

T-Shirt Design

Participants design the Colorado delegation’s national conference T-shirt. The winner between the middle and high school top finishers will become the state delegation T-shirt. **NOTE: Due to the complexity and the large number of entries in this event as well as the limited duration of the state conference, this event has an early submission deadline! Contestants should submit entry as a single, multi-page PDF file via the COTSA State Conference Early Submission Entry Form located at: <http://goo.gl/hwsZvG> by 11:59 p.m. on February 1, 2017. Contestants will need to enter their STATE CONFERENCE ID# when submitting their entry. Entries not submitted electronically or are not received by the deadline will NOT be considered for competition.**

Limited to: One (1) entry per student.



Theatrical Set Design (*NEW EVENT!*)

Participants develop a set of architectural plans and related materials for an annual theatrical set design challenge and construct a physical, as well as computer-generated model to accurately depict their design. For 2016-17, the set design is based on the play, “Arsenic and Old Lace.”

Limited at State to: One (1) team of two to six (2-6) students per chapter.

Underwater ROV Challenge

Participants apply and document the engineering design process, mathematical principles and scientific concepts used in the research, design, construction, testing and evaluation of an underwater remote operated vehicle (ROV). The ROV will be expected to perform a range of tasks may include, but are not limited to: navigating an obstacle course, retrieving items from the pool, entering enclosed spaces, and/or demonstrating full maneuverability in three axes of motion.

Limited to: Two (2) teams of two to six (2-6) students per chapter.



Early Deadline Events - Middle School

The events listed below have an early submission deadline of February 1, 2017. Along with each event listed is a brief summary of what is to be submitted and in what format. All early submissions (both PDFs and URLs) are to be uploaded via the COTSA State Conference Early Submission Entry Form located at: <http://goo.gl/hwsZvG> by 11:59 p.m. by February 1, 2017. Contestants will need to enter their STATE CONFERENCE ID# when submitting their entries.

MIDDLE SCHOOL	
Event	What to Submit
Career Prep	Resume & letter of introduction as a single, multi-page PDF document.
Children's Stories	Story and illustrations, along with required research documentation should be submitted as a single, multi-page PDF document.
Community Service Video	<i>VIDEO:</i> Video is required to be uploaded to YouTube as an unlisted video. URL to video is to be submitted online via the COTSA Early Submission Entry Form. <i>DOCUMENTATION:</i> The required documentation portfolio as described in the rules (including consent/photo release forms) is to be submitted as a single, multi-page PDF document.
Digital Photography	Photo album as described in the rules (including consent/photo release forms) is to be submitted as a single, multi-page PDF document.
Environmental Engineering	<i>MULTIMEDIA PRESENTATION:</i> Presentation is required to be uploaded to YouTube as a video as an unlisted video. URL to presentation is to be submitted online via the COTSA Early Submission Entry Form. <i>DOCUMENTATION:</i> The required documentation portfolio as described in the rules is to be submitted as a single, multi-page PDF document.
Integrated Autonomous Vehicle	<i>DOCUMENTATION:</i> The technical documentation should be made available electronically through a website or blog (e.g., Instructables, Google Sites, wix.com, Blogger, Wordpress, etc.). The URL to the website or blog is to be submitted online via the COTSA Early Submission Entry Form.
Pin Design	Portfolio as described in the rules is to be submitted as a single, multi-page PDF document.
Promotional Marketing	Portfolio as described in the rules is to be submitted as a single, multi-page PDF document.

Continued on next page



Early Deadline Events - Middle School

Continued from previous page

MIDDLE SCHOOL	
EVENT	WHAT TO SUBMIT
Silent Movie	<p><i>VIDEO:</i> Video is required to be uploaded to YouTube as an unlisted video. URL to video is to be submitted online via the COTSA Early Submission Entry Form.</p> <p><i>DOCUMENTATION:</i> The required documentation portfolio as described in the rules (including consent/photo release forms) is to be submitted as a single, multi-page PDF document.</p>
STEM Animation	<p><i>ANIMATION:</i> The animation is required to be uploaded to YouTube as an unlisted video. The URL is to be submitted online via the COTSA Early Submission Entry Form.</p> <p><i>DOCUMENTATION:</i> The required documentation as described in the rules is to be submitted as a single, multi-page PDF document.</p>
T-Shirt Design	Design and required documentation as described in the rules is to be uploaded to the online Early Submission Entry Form as a single, multi-page PDF document.
Underwater ROV	Documentation portfolio as described in the rules is to be submitted as a single, multi-page PDF document via the Early Submission Entry Form.
Video Game Design	<p><i>VIDEO GAME:</i> The URL of the video game is to be submitted online via the COTSA Early Submission Entry form.</p> <p><i>DOCUMENTATION:</i> The required documentation portfolio as described in the rules is to be submitted as a single, multi-page PDF document.</p>
Website Design	The URL is to be submitted via the online Early Submission Entry Form.



Early Deadline Events - High School

The events listed below have an early submission deadline of February 1, 2017. Along with each event listed is a brief summary of what is to be submitted and in what format. All early submissions (both PDFs and URLs) are to be uploaded via the COTSA State Conference Early Submission Entry Form located at: <http://goo.gl/hwsZvG> by 11:59 p.m. February 1, 2017. Contestants will need to enter their STATE CONFERENCE ID# when submitting their entries.

HIGH SCHOOL	
Event	What to Submit
3D Animation	<p><i>ANIMATION:</i> Video is required to be uploaded to YouTube as an unlisted video. The URL to video is to be submitted online via the COTSA Early Submission Entry Form.</p> <p><i>DOCUMENTATION:</i> The required documentation portfolio as described in the rules (including consent/photo release forms) is to be submitted as a single, multi-page PDF document is to be submitted via the Early Submission Entry Form.</p>
Digital Video Production	<p><i>VIDEO:</i> Video is required to be uploaded to YouTube as an unlisted video. The URL to video is to be submitted online via the COTSA Early Submission Entry Form.</p> <p><i>DOCUMENTATION:</i> The required documentation portfolio as described in the rules (including consent/photo release forms) is to be submitted as a single, multi-page PDF document is to be submitted via the Early Submission Entry Form.</p>
Future Technology Teacher	Portfolio containing two (2) college research summaries, a college essay, a letter of recommendation, lesson plan with technology standards correlation, relevant handouts, and materials and resources as a single- multi-page PDF document.
Integrated Autonomous Vehicle	<i>DOCUMENTATION:</i> The design process should be made available electronically through a website or blog (e.g., Instructables, Google Sites, wix.com, Blogger, Wordpress, etc.). The URL to the website or blog is to be submitted online via the COTSA Early Submission Entry Form.
Music Production	<p><i>MUSIC:</i> Music is to be uploaded as an MP3 or WAV file via the online Early Submission Entry Form.</p> <p><i>DOCUMENTATION:</i> The required documentation portfolio as described in the rules (including consent/release forms) is to be submitted as a single, multi-page PDF document via the Early Submission Entry Form.</p>
Photographic Technology	Photo album as described in the rules as a single, multi-page PDF document is to be submitted via the Early Submission Entry Form.

Continued on next page



Early Deadline Events - High School

Continued from previous page

HIGH SCHOOL	
Pin Design	Design and related documentation as a single, multi-page PDF document is to be submitted via the Early Submission Entry Form..
Promotional Design	Design and documentation portfolio as described in the rules as a single, multi-page PDF document online via the COTSA Early Submission Entry Form.
SCIVIS	VISUALIZATION: The visualization is required to be uploaded to YouTube as an unlisted video. The URL is to be submitted via the online Early Submission Entry Form. DOCUMENTATION: The required documentation as described in the rules is to be submitted as a single, multi-page PDF document.
Silent Movie	<i>VIDEO:</i> Video is required to be uploaded to YouTube as an unlisted video. The URL to video is to be submitted online via the COTSA Early Submission Entry Form. <i>DOCUMENTATION:</i> The required documentation portfolio as described in the rules (including consent/photo release forms) is to be submitted as a single, multi-page PDF document is to be submitted via the Early Submission Entry Form.
Software Development	<i>DOCUMENTATION:</i> The required documentation portfolio (including source code) as described in the rules is to be submitted as a single, multi-page PDF document via the Early Submission Entry Form.
STEM Careers	<i>VIDEO:</i> The video is required to be uploaded to YouTube as an unlisted video. The URL is to be submitted via the online Early Submission Entry Form. <i>DOCUMENTATION:</i> The required documentation as described in the rules is to be submitted as a single, multi-page PDF document.
T-Shirt Design	Design and required documentation as described in the rules is to be uploaded to the online Early Submission Entry Form as a single, multi-page PDF document.
Underwater ROV	Documentation portfolio as described in the rules is to be submitted as a single, multi-page PDF document online via the COTSA Early Submission Entry Form.
Video Game Design	The required documentation portfolio as described in the rules is to be submitted as a single, multi-page PDF document. The video game itself is NOT to be submitted.
Webmaster	The URL is to be submitted via the online Early Submission Entry Form.



Middle School Event Eligibility

Below, please find the number of entries that may be submitted for events at both the STATE and National Conferences.

NATIONAL EVENTS		
EVENT	AT STATE	AT NATIONALS
Biotechnology	3 teams of 2-6 students per chapter	3 teams of 2-6 per state
CAD Foundations	2 students per chapter	2 students per state
Career Prep	1 entry per student	1 student per chapter
Catapult Design	3 teams of 2-4 students per chapter	3 teams of 2-4 students per state
Challenging Tech Issues	3 teams of 2 students per chapter	3 teams of 2 students per state
Chapter Team	1 team of 6 students per chapter	1 team of 6 students per chapter
Children's Stories	3 teams of 1-6 students per chapter	1 team of 1-6 per chapter
Community Service Video	1 team of 1-6 students per chapter	1 team of 1-6 students per chapter
Construction Challenge	3 teams of 2-6 students per chapter	1 team of 2-6 students per chapter
Digital Photography	2 students per chapter	3 students per state
Dragster	3 students per chapter	2 students per chapter
Electrical Applications	3 students per chapter	2 students per chapter
Environmental Engineering	1 team of 2-6 students per chapter	1 team of 2-6 students per chapter
Essays on Technology	3 students per chapter	3 students per state
Flight	6 students per chapter	2 students per chapter
Forensic Technology	1 team of 2 students per chapter	1 team of 2 per chapter
Geospatial Technology	1 team of 2-5 students per chapter	1 team of 2-5 students per chapter
Inventions & Innovations	3 teams of 3-6 students per chapter	1 team of 3-6 students per chapter
Junior Solar Sprint	1 team of 2-4 students per chapter	1 team of 2-4 students per chapter
Leadership Strategies	3 teams of 3 students per chapter	1 team of 3 students per chapter
Mass Production	1 team of 2-6 students per chapter	1 team of 2-6 students per chapter



NATIONAL EVENTS		
EVENT	AT STATE	AT NATIONALS
Medical Technology Issues	3 teams of 2-6 students per chapter	3 teams of 2-6 students per state
Microcontroller Design	1 team of 3-5 students per chapter	1 team of 3-5 students per chapter
Prepared Speech	3 students per chapter	1 student per chapter
Problem Solving	2 teams of 2 students per chapter	1 team of 2 students per chapter
Promotional Marketing	6 students per chapter	1 student per chapter
STEM Animation	6 teams of 1-6 students per chapter	3 teams of 1-6 per state
Structural Engineering	2 teams of 2 students per chapter	1 team of 2 students per chapter
System Control Technology	1 team of 3 students per chapter	1 team of 3 students per state
Tech Bowl	1 team of 3 students per chapter	1 team of 3 students per chapter
Technical Design	2 teams of 2 students per chapter	1 team of 2 students per chapter
Video Game Design	1 team of 2-6 students per chapter	1 team of 2-6 students per chapter
Website Design	1 team of 3-6 students per chapter	1 team of 3-6 students per chapter

STATE ONLY EVENTS	
EVENT	AT STATE
Crash Test	10 teams of 2 students per chapter - 1 must be an elementary student
Fashion Design	2 teams of 2-4 students per chapter
Giant Jenga Tournament	4 teams of 2-4 students per chapter
Integrated Autonomous Vehicle	2 teams of 3 per chapter
Middle School Creativity Challenge	10 teams of 2 students per chapter - 1 must be an elementary student
Mousetrap Tractor Pull	6 students per chapter
On-Demand Video	1 team of 2-6 students per chapter
Pin Design	1 entry per student
Rubber Band Powered Cars	3 students per chapter
Silent Movie	1 team of 2-6 students per chapter
T-Shirt Design	1 entry per student
Underwater ROV	2 teams of 2-6 students per chapter



High School Event Eligibility

Below, please find the number of entries that may be submitted for events at both the STATE and National Conferences.

NATIONAL EVENTS		
EVENT	AT STATE	AT NATIONALS
3D Animation	3 teams of 2 per chapter	3 teams of 2 per state
Animatronics	2 teams of 2-6 students per chapter	1 team of 2-6 students per chapter
Architectural Design	3 teams of 1-6 students per chapter	1 team of 1-6 students per chapter
Biotechnology Design	3 teams of 2-6 per chapter	3 teams of 2-6 students per state
Chapter Team	1 team of 6 students per chapter	1 team of 6 students per chapter
Children's Stories	3 teams of 1-6 students per chapter	1 team of 1-6 students per chapter
Coding	2 individuals or 2 teams of 2-3 students per chapter	1 individual or 1 team of 2-3 students per chapter
Computer Aided Design - Architecture	3 students per chapter	2 students per state
Computer Aided Design - Engineering	3 students per chapter	2 students per state
Computer Integrated Manufacturing	3 teams of 2 students per chapter	1 team of 2 students per chapter
Debating Technological Issues	1 team of 2 members per chapter	3 teams of 2 students per state
Digital Video Production	3 teams of 1-6 students per chapter	3 teams of 1-6 students per state
Dragster Design	3 students per chapter	2 students per chapter
Engineering Design	3 teams of 3-6 students per chapter	1 team of 3-6 students per chapter
Essays on Technology	3 students per chapter	3 students per state
Extemporaneous Presentation	3 students per chapter	3 students per state
Fashion Design & Technology	2 teams of 2-4 students per chapter	3 teams of 2-4 students per state
Flight Endurance	3 students per chapter	2 students per chapter
Future Technology Teacher	3 students per chapter	3 students per chapter
Music Production	6 teams of 1-6 per chapter	3 teams of 1-6 per state



NATIONAL EVENTS		
EVENT	AT STATE	AT NATIONALS
On-Demand Video	1 team of 2-6 students per chapter	1 team of 2-6 students per chapter
Photographic Technology	2 students per chapter	1 student per chapter
Prepared Presentation	3 students per chapter	3 students per state
Promotional Design	6 students per chapter	3 students per state
SciVis	3 teams of 1-6 students per chapter	3 teams of 1-6 per state
Software Development	1 team of 2-6 students per chapter	1 team of 2-6 students per chapter
STEM Careers	6 students per chapter	6 students per state
Structural Design & Engineering	2 teams of 2 students per chapter	1 team of 2 students per chapter
System Control Technology	1 team of 3 students per chapter	1 team of 3 students per state
Technology Bowl	1 team of 3 students per chapter	1 team of 3 students per chapter
Technology Problem Solving	2 teams of 2 students per chapter	1 team of 2 students per chapter
Transportation Modeling	3 students per chapter	1 student per chapter
Video Game Design	2 teams of 2-6 students per chapter	3 teams of 2-6 students per state
Webmaster	1 team of 3-5 students per chapter	1 team of 3-5 students per chapter

STATE ONLY EVENTS	
EVENT	AT STATE
Catapult Design	3 teams of 2-4 students per chapter
Fore!	10 teams of 2 students per chapter - 1 must be an elementary student
Giant Jenga Tournament	4 teams of 2-4 students per chapter
High School Creativity Challenge	10 teams of 2 students per chapter - 1 must be an elementary student
Integrated Autonomous Vehicle	2 teams of 3 students per chapter
Pin Design	1 entry per student
Rat Trap Drag Races	6 students per chapter
Rubber Band Powered Cars	3 students per chapter
Silent Movie	1 team of 2-6 students per chapter
T-Shirt Design	1 entry per student
Theatrical Set Design	1 team of 2-6 students per chapter
Underwater ROV	2 teams of 2-6 students per chapter



Notes:

